

µP Supervisory Circuit

- Edge Triggered, Single Pulse Manual Reset
- Guaranteed \overline{MR} Disable Period

The IMP161 and IMP162 are low power supervisory circuits that monitor power supplies in microprocessor based systems. If the power supply drops below the reset threshold level, a reset is asserted and remains asserted for at least 800ms after V_{CC} has risen above the reset threshold. An improved manual reset architecture gives the system designer additional flexibility.

The debounced manual reset input is negative edge triggered. The reset pulse period generated by a \overline{MR} transition is a minimum of 800ms and maximum of 2 sec. In addition, the \overline{MR} input signal is blocked for an additional 49µS minimum after the reset pulse ends. During the \overline{MR} disable period, the microcontroller is guaranteed a time period free of additional manual reset signals. During this period DRAM contents can be refreshed or other critical system tasks undertaken.

Low supply current makes the IMP161/162 ideal for use in battery operated equipment. With 3V supplies power consumption is 8µW typically and 30µW maximum.

The IMP161 has an open-drain, active-LOW \overline{RESET} output and uses an external pull-up resistor. The IMP162 has an active-HIGH RESET output.

Available in compact 4-pin SOT-143 packages, six voltage thresholds are offered to support 3.0V, 3.3V and 5V power systems.

Reset Thresholds	
Part Suffix	Voltage
L	4.63V
M	4.38V
J	4.00V
T	3.08V
S	2.93V
R	2.63V

Key Features

- ◆ Edge triggered manual reset input
 - Single pulse output
 - 49µS minimum \overline{MR} disable period after reset
 - CMOS/TTL logic or switch interface
 - Debounced input
- ◆ Low supply current extends battery life
 - 6µA/15µA typ/max at 5.5V
 - 4.5µA/10µA typ/max at 3.6V
- ◆ Long reset period
 - 0.8 sec minimum, 2 sec maximum
- ◆ Two reset polarity options
 - IMP161: Active LOW, open-drain
 - IMP162: Active HIGH
- ◆ Pinout matches the IMP811/812
- ◆ Small 4-pin SOT-143 package

Applications

- ◆ PDAs
- ◆ Appliances
- ◆ Computers and embedded controllers
- ◆ Wireless communication systems
- ◆ Embedded control systems
- ◆ Battery-operated systems
- ◆ Intelligent instruments

Block Diagrams

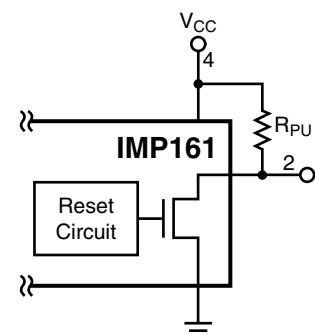
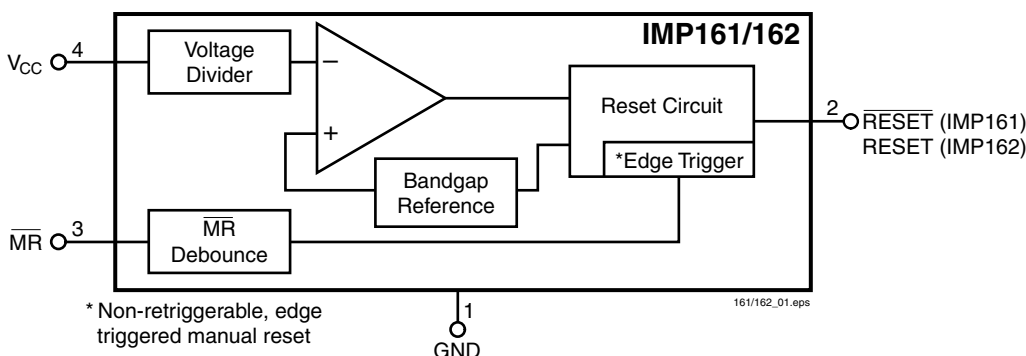

Pin Configuration

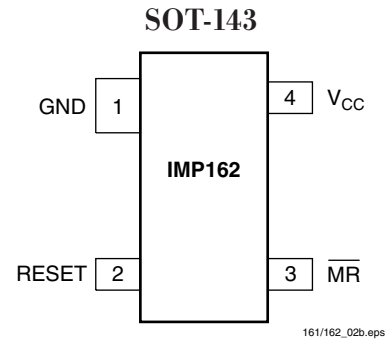
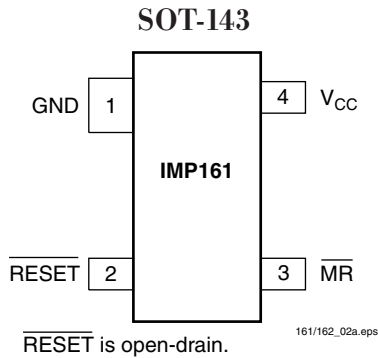

Ordering Information

Part Number ¹	Reset Threshold (V)	Temperature Range	Pin-Package	Package Marking (XX Lot Code)
IMP161LCUS/T	4.63	0°C to 70°C	4-SOT143	1 LXX
IMP161MCUS/T	4.38	0°C to 70°C	4-SOT143	1 MXX
IMP161JCUS/T	4.00	0°C to 70°C	4-SOT143	1 JXX
IMP161TCUS/T	3.08	0°C to 70°C	4-SOT143	1 TXX
IMP161SCUS/T	2.93	0°C to 70°C	4-SOT143	1 SXX
IMP161RCUS/T	2.63	0°C to 70°C	4-SOT143	1 RXX
IMP162LCUS/T	4.63	0°C to 70°C	4-SOT143	2 LXX
IMP162MCUS/T	4.38	0°C to 70°C	4-SOT143	2 MXX
IMP162JCUS/T	4.00	0°C to 70°C	4-SOT143	2 JXX
IMP162TCUS/T	3.08	0°C to 70°C	4-SOT143	2 TXX
IMP162SCUS/T	2.93	0°C to 70°C	4-SOT143	2 SXX
IMP162RCUS/T	2.63	0°C to 70°C	4-SOT143	2 RXX
IMP161LEUS/T	4.63	-40°C to 85°C	4-SOT143	3 LXX
IMP161MEUS/T	4.38	-40°C to 85°C	4-SOT143	3 MXX
IMP161JEUS/T	4.00	-40°C to 85°C	4-SOT143	3 JXX
IMP161TEUS/T	3.08	-40°C to 85°C	4-SOT143	3 TXX
IMP161SEUS/T	2.93	-40°C to 85°C	4-SOT143	3 SXX
IMP161REUS/T	2.63	-40°C to 85°C	4-SOT143	3 RXX
IMP162LEUS/T	4.63	-40°C to 85°C	4-SOT143	4 LXX
IMP162MEUS/T	4.38	-40°C to 85°C	4-SOT143	4 MXX
IMP162JEUS/T	4.00	-40°C to 85°C	4-SOT143	4 JXX
IMP162TEUS/T	3.08	-40°C to 85°C	4-SOT143	4 TXX
IMP162SEUS/T	2.93	-40°C to 85°C	4-SOT143	4 SXX
IMP162REUS/T	2.63	-40°C to 85°C	4-SOT143	4RXX

Notes: 1. Tape and Reel packaging is indicated by the /T designation.

161/162_105_ens

Absolute Maximum Ratings

Pin Terminal Voltage with Respect to Ground

V_{CC} -0.3V to 6.0V
 $\overline{\text{RESET}}$, $\overline{\text{RESET}}$ and $\overline{\text{MR}}$ -0.3V to ($V_{CC} + 0.3V$)
 Input Current at V_{CC} and $\overline{\text{MR}}$ 20mA
 Output Current: $\overline{\text{RESET}}$ or $\overline{\text{RESET}}$ 20mA
 Rate of Rise at V_{CC} 100V/ μs

Power Dissipation ($T_A = 70^\circ\text{C}$) 320mW
 Operating Temperature Range 0°C to 70°C
 Storage Temperature Range -65°C to 160°C
 Lead Temperature (soldering, 10 sec) 300°C

These are stress ratings only and functional operation is not implied. Exposure to absolute maximum ratings for prolonged time periods may affect device reliability

Electrical Characteristics

Unless otherwise noted V_{CC} is over the full voltage range and $T_A = 0^\circ\text{C}$ to 70°C for IMP161/2xC and $T_A = -40^\circ\text{C}$ to 85°C for IMP161/2xE devices. Typical values at $T_A = 25^\circ\text{C}$, $V_{CC} = 5\text{V}$ for L/M/J devices, $V_{CC} = 3.3\text{V}$ for T/S devices and $V_{CC} = 3\text{V}$ for R devices.

Parameter	Symbol	Conditions	Min	Typ	Max	Units		
Input Voltage (V_{CC}) Range	V_{CC}	$T_A = 0^\circ\text{C}$ to 70°C	1.1		5.5	V		
Supply Current (Unloaded)	I_{CC}	$T_A = 0^\circ\text{C}$ to 70°C $T_A = 0^\circ\text{C}$ to 70°C		6 4.5	15 10	μA		
		$T_A = -40^\circ\text{C}$ to 85°C $T_A = -40^\circ\text{C}$ to 85°C	$V_{CC} < 5.5\text{V}$, L/M/J $V_{CC} < 3.6\text{V}$, R/S/T	6 4.5	15 10			
Reset Threshold	V_{TH}	L devices	$T_A = 25^\circ\text{C}$ Note 1	4.56 4.50	4.63 4.75	V		
		M devices	$T_A = 25^\circ\text{C}$ Note 1	4.31 4.25	4.38 4.50			
		J devices	$T_A = 25^\circ\text{C}$ Note 1	3.93 3.89	4.00 4.10			
		T devices	$T_A = 25^\circ\text{C}$ Note 1	3.04 3.00	3.08 3.15			
		S devices	$T_A = 25^\circ\text{C}$ Note 1	2.89 2.85	2.93 3.00			
		R devices	$T_A = 25^\circ\text{C}$ Note 1	2.59 2.55	2.63 2.70			
Reset Threshold Temp. Coefficient	$TC_{V_{TH}}$			30		ppm/ $^\circ\text{C}$		
V_{CC} to Reset Delay		$V_{CC} = V_{TH}$ to $(V_{TH} - 100\text{mV})$		20		μs		
Reset Pulse Width	t_{PWR}	$T_A = 0^\circ\text{C}$ to 70°C	800	1400	2000	ms		
		$T_A = -40^\circ\text{C}$ to 85°C	560		2240			
$\overline{\text{MR}}$ Minimum Pulse Width	t_{MR}		10			μs		
$\overline{\text{MR}}$ Glitch Immunity				100		ns		
$\overline{\text{MR}}$ to RESET Propagation Delay	t_{MD}			0.5		μs		
$\overline{\text{MR}}$ Input Threshold	V_{IH}	$V_{CC} > V_{TH}(\text{MAX})$, L/M/J devices	2.3		0.8	V		
	V_{IL}							
	V_{IH}	$V_{CC} > V_{TH}(\text{MAX})$, R/S/T devices					0.7 V_{CC}	
	V_{IL}							0.25 V_{CC}
$\overline{\text{MR}}$ Delay to MR Retrigger	t_{MRD}	$T_A = 0^\circ\text{C}$ to 70°C	49	85	122	μs		
		$T_A = -40^\circ\text{C}$ to 85°C		85				
$\overline{\text{MR}}$ Pull-up Resistance			10	20	30	k Ω		
Low RESET Output Voltage (IMP161)	V_{OL}	$V_{CC} = V_{TH} \text{ min.}$, $I_{SINK} = 1.2\text{mA}$, IMP161R/S/T			0.3	V		
		$V_{CC} = V_{TH} \text{ min.}$, $I_{SINK} = 3.2\text{mA}$, IMP161L/M/J			0.4			
		$V_{CC} > 1.1\text{V}$, $I_{SINK} = 50\mu\text{A}$			0.3			
RESET Output Leakage Current (IMP161)	I_{LKG}	$V_{DRAIN} \leq 6.0\text{V}$, $0^\circ\text{C} \leq T_A \leq 70^\circ\text{C}$			1	μA		
Low RESET Output Voltage (IMP162)	V_{OL}	$V_{CC} = V_{TH} \text{ max.}$, $I_{SINK} = 1.2\text{mA}$, IMP162R/S/T			0.3	V		
		$V_{CC} = V_{TH} \text{ max.}$, $I_{SINK} = 3.2\text{mA}$, IMP162L/M/J			0.4			
High RESET Output Voltage (IMP162)	V_{OH}	$1.8\text{V} < V_{CC} < V_{TH} \text{ min.}$, $I_{SOURCE} = 150\mu\text{A}$	0.8 V_{CC}			V		

Notes: 1. Over operating temperature range.

161/162_101.eps

Pin Descriptions

Pin Number		Name	Description
IMP161	IMP162		
1	1	GND	Ground.
2		$\overline{\text{RESET}}$	Active-LOW, open-drain reset output. $\overline{\text{RESET}}$ remains LOW while V_{CC} is below the reset threshold and for 800ms minimum after V_{CC} rises above the reset threshold. An external pull-up resistor is needed.
	2	RESET	Active-HIGH Reset output. RESET remains HIGH while V_{CC} is below the reset threshold and for 800ms after V_{CC} rises above the reset threshold.
3	3	$\overline{\text{MR}}$	Manual Reset input. A negative going edge transition on $\overline{\text{MR}}$ asserts reset. Reset remains asserted for one reset time-out period (800ms min). This active-LOW input has an internal pull-up resistor. It can be driven from a TTL or CMOS logic line or shorted to ground with a switch. Leave open if unused.
4	4	V_{CC}	Power supply input voltage.

161/162_102.eps

Application Information

Reset Generation

The reset function ensures the microprocessor is properly reset and powers up into a known condition after a power failure.

A reset is generated whenever the supply voltage is below the threshold level ($V_{CC} < V_{TH}$). The reset duration is at least 800ms after V_{CC} has risen above the reset threshold and is guaranteed to be no more than 2 seconds. The reset signal remains active as long as the monitored supply voltage is below the internal threshold voltage.

The IMP161 has an open-drain, active-LOW $\overline{\text{RESET}}$ output (which is guaranteed to be in the correct state for V_{CC} down to 1.1V). The IMP161 uses an external pull-up resistor. Output leakage current is under 1 μ A. A high resistance value can be used to minimize current drain.

The IMP162 has an active-HIGH RESET output.

IMP Part Number	Reset Polarity
IMP161	LOW (use external pull-up resistor)
IMP162	HIGH

161/162_103.eps

Manual Reset

The IMP161/162 have a unique manual reset circuit. A negative going edge transition on $\overline{\text{MR}}$ initiates the reset. A manual reset generates a single reset pulse of fixed length. The output-reset pulse remains asserted for the Reset Active Time-Out Period t_{RPW} and then clears. Once the reset pulse is completed, the $\overline{\text{MR}}$ input remains disabled for at least 49 μ s but not more than 122 μ s. This period is specified as t_{MRD} .

During the $\overline{\text{MR}}$ disable period, the microcontroller is guaranteed a time period free of new manual reset signals. This period can be used to refresh critical DRAM contents or other system tasks.

The $\overline{\text{MR}}$ pin must be taken HIGH and LOW again after the t_{MRD} period has been completed to initiate another reset pulse.

The manual reset input has an internal 20-k Ω pull-up resistor. $\overline{\text{MR}}$ can be left open if not used.

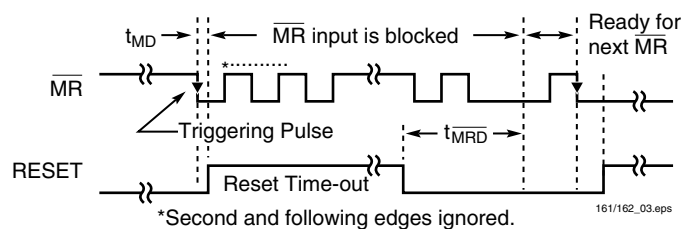

Figure 1. Manual Reset Timing and $\overline{\text{MR}}$ Block Out Period

Application Information

Glitch Resistance

The IMP161/162 are relatively immune to short duration negative-going V_{CC} transients/glitches. A V_{CC} transient that goes 100mV below the reset threshold and lasts 20 μ s or less will not typically cause a reset pulse.

Valid Reset with V_{CC} under 1.1V

To ensure that logic inputs connected to the IMP161 $\overline{\text{RESET}}$ pin are in a known state when V_{CC} is under 1.1V, a 100k Ω pull-down resistor at $\overline{\text{RESET}}$ is needed. The value is not critical.

A similar pull-up resistor to V_{CC} is needed with the IMP162.

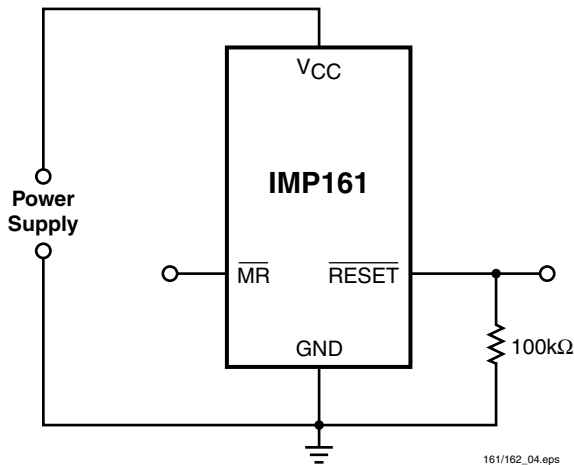

Figure 2. RESET Valid with V_{CC} Under 1.1V

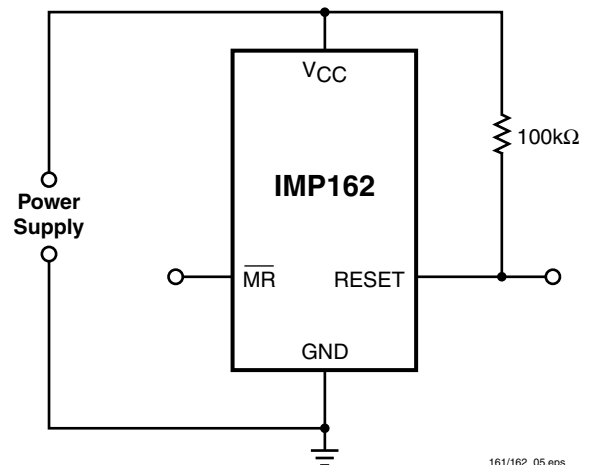
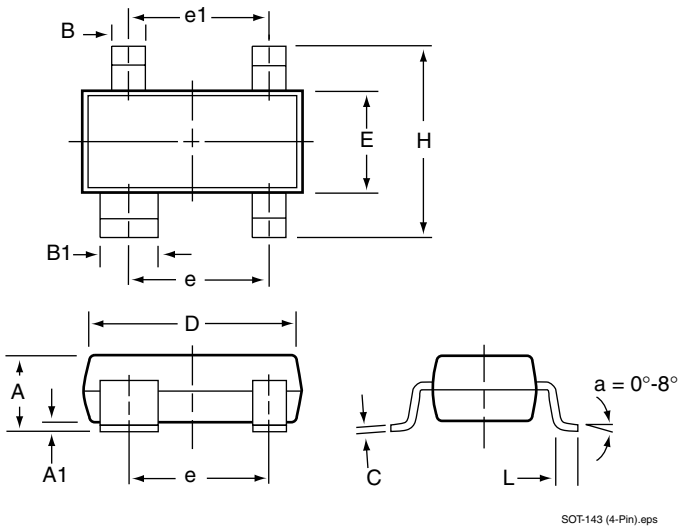

Figure 3. RESET Valid with V_{CC} Under 1.1V

Package Dimensions

Plastic SOT-143 (4-Pin)



	Inches		Millimeters	
	Min	Max	Min	Max
Plastic SOT-143 (4-Pin)				
A	0.031	0.047	0.787	1.194
A1	0.001	0.005	0.025	0.127
B	0.014	0.022	0.356	0.559
B1	0.030	0.038	0.762	0.965
C	0.0034	0.006	0.086	0.152
D	0.105	0.120	2.667	3.048
E	0.047	0.055	1.194	1.397
e	0.070	0.080	1.778	2.032
e1	0.071	0.079	1.803	2.007
H	0.082	0.098	2.083	2.489
I	0.004	0.012	0.102	0.305

161/162_104.eps