

POWER MANAGEMENT

Supervisors

IMP1810 – Low Power, 5V μ P Reset
Active LOW, Push-Pull Output

IMP1811 – Low Power, 5V μ P Reset
Active LOW, Open-Drain Output

IMP1812 – Low Power, 5V μ P Reset
Active HIGH, Push-Pull Output

IMP1815 – Low Power, 3.3V/3.0V μ P Reset
Active LOW, Push-Pull Output

IMP1816 – Low Power, 3.3V/3.0V μ P Reset
Active LOW, Open-Drain Output

IMP1817 – Low Power, 3.3V/3.0V μ P Reset
Active HIGH, Push-Pull Output

IMP1233D – Low Power, 5V μ P Reset
Active LOW, Open-Drain Output

IMP1233M – Low Power, 5V/3.0V μ P Reset
Active LOW, Open-Drain Output

μP Supervisor Products: Low Power Alternatives to Dallas Semiconductor

IMP Ordering Part Number	RESET Voltage (V)	RESET Tolerance (%)	RESET Time (ms)	RESET Polarity	Push-Pull Output Stage	Open Drain Output	8-Pin SO Package	TO-92 Package	SOT-23 Package	SOT-223 Package
IMP1810-5	4.620	5	150	LOW	X			X		
IMP1810-10	4.370	10	150	LOW	X			X		
IMP1810-15	4.120	15	150	LOW	X			X		
IMP1810R-5	4.620	5	150	LOW	X				X	
IMP1810R-10	4.370	10	150	LOW	X				X	
IMP1810R-15	4.120	15	150	LOW	X				X	
IMP1811-5	4.620	5	150	LOW		X		X		
IMP1811-10	4.350	10	150	LOW		X		X		
IMP1811-15	4.130	15	150	LOW		X		X		
IMP1811R-5	4.620	5	150	LOW		X			X	
IMP1811R-10	4.350	10	150	LOW		X			X	
IMP1811R-15	4.130	15	150	LOW		X			X	
IMP1812-5	4.620	5	150	HIGH	X			X		
IMP1812-10	4.350	10	150	HIGH	X			X		
IMP1812-15	4.130	15	150	HIGH	X			X		
IMP1812R-5	4.620	5	150	HIGH	X				X	
IMP1812R-10	4.350	10	150	HIGH	X				X	
IMP1812R-15	4.130	15	150	HIGH	X				X	
IMP1815-5	3.060	5	150	LOW	X			X		
IMP1815-10	2.880	10	150	LOW	X			X		
IMP1815-20	2.550	20	150	LOW	X			X		
IMP1815R-5	3.060	5	150	LOW	X				X	
IMP1815R-10	2.880	10	150	LOW	X				X	
IMP1815R-20	2.550	20	150	LOW	X				X	
IMP1816-5	3.060	5	150	LOW		X		X		
IMP1816-10	2.880	10	150	LOW		X		X		
IMP1816-20	2.550	20	150	LOW		X		X		
IMP1816R-5	3.060	5	150	LOW		X			X	
IMP1816R-10	2.880	10	150	LOW		X			X	
IMP1816R-20	2.550	20	150	LOW		X			X	
IMP1817-5	3.060	5	150	HIGH	X			X		
IMP1817-10	2.880	10	150	HIGH	X			X		
IMP1817-20	2.550	20	150	HIGH	X			X		
IMP1817R-5	3.060	5	150	HIGH	X				X	
IMP1817R-10	2.880	10	150	HIGH	X				X	
IMP1817R-20	2.550	20	150	HIGH	X				X	
IMP1233D-5	4.625	5	350	LOW		X		X		
IMP1233D-10	4.375	10	350	LOW		X		X		
IMP1233D-15	4.125	15	350	LOW		X		X		
IMP1233DZ-5	4.625	5	350	LOW		X				X
IMP1233DZ-10	4.375	10	350	LOW		X				X
IMP1233DZ-15	4.125	15	350	LOW		X				X
IMP1233M-55	4.625	5	350	LOW		X		X		
IMP1233M-5	4.375	10	350	LOW		X		X		
IMP1233M-3	2.720	15	350	LOW		X		X		
IMP1233MS-55	4.625	5	350	LOW		X	X			
IMP1233MS-5	4.375	10	350	LOW		X	X			
IMP1233MS-3	2.720	15	350	LOW		X	X			

ELD/B_107

POWER MANAGEMENT

Low Power, 5V μ P Reset – Active LOW, Push-Pull Output

The IMP1810 supply voltage monitor is an improved, low-power replacement for the Dallas Semiconductor DS1810. Maximum supply current over temperature is a low 20 μ A, representing 50 percent lower power as compared to the DS1810.

The IMP1810 issues an active LOW reset signal whenever the monitored supply is out-of-tolerance. A precision reference and comparator circuit monitor power supply (V_{CC}) level. Tolerance level options are 5-, 10- and 15-percent. When an out-of-tolerance condition is detected, an internal power-fail signal is generated which forces an active LOW reset signal. After V_{CC} returns to an in-tolerance condition, the reset signal remains active for 150ms to allow the power supply and system microprocessor to stabilize.

The IMP1810 is designed with a push-pull output stage and operates over the extended industrial temperature range. Devices are available in compact surface mount SOT-23 packages and 3-lead TO-92 packages.

Other low power products in this family include the IMP1811/12/15/16/17, IMP1233D and IMP1233M.

Key Features

- ◆ Improved Dallas DS1810 replacement
 - 50% lower maximum supply current
- ◆ Low Supply Current
 - 20 μ A maximum (5.5V)
- ◆ Automatically restarts a microprocessor after power failure
- ◆ 150ms reset delay after V_{CC} returns to an in-tolerance condition
- ◆ Active LOW power-up reset
- ◆ Precision temperature-compensated voltage reference and comparator
- ◆ Eliminates external components
- ◆ Low-cost TO-92 package
- ◆ Compact surface mount SOT-23 package
- ◆ Push-Pull output for minimum current drain
- ◆ Operating temperature -40°C to $+85^{\circ}\text{C}$

Family Selection Guide

Part	RESET Voltage (V)	RESET Time (ms)	Output Stage	RESET Polarity
IMP1810	4.620, 4.370, 4.120	150	Push-Pull	LOW
IMP1811	4.620, 4.350, 4.130	150	Open-Drain	LOW
IMP1812	4.620, 4.350, 4.130	150	Push-Pull	HIGH
IMP1815	3.060, 2.880, 2.550	150	Push-Pull	LOW
IMP1816	3.060, 2.880, 2.550	150	Open-Drain	LOW
IMP1817	3.060, 2.880, 2.550	150	Push-Pull	HIGH
IMP1233D	4.625, 4.375, 4.125	350	Open-Drain	LOW
IMP1233M	4.625, 4.375, 2.720	350	Open-Drain	LOW

Applications

- ◆ Set-top boxes
- ◆ Cellular phones
- ◆ PDAs
- ◆ Energy management systems
- ◆ Embedded control systems
- ◆ Printers
- ◆ Single board computers

Block Diagram

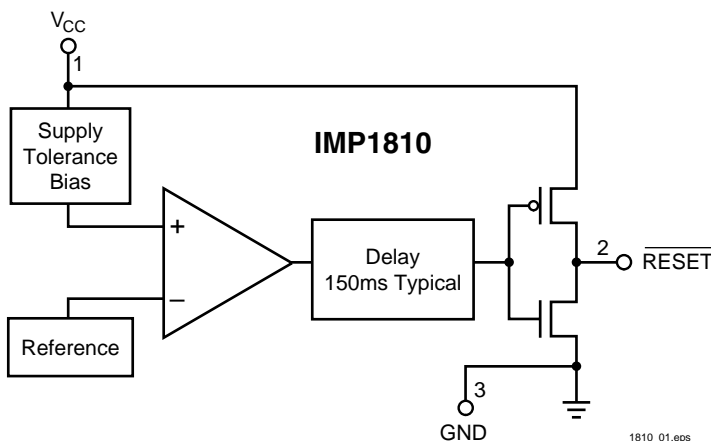

Typical Application

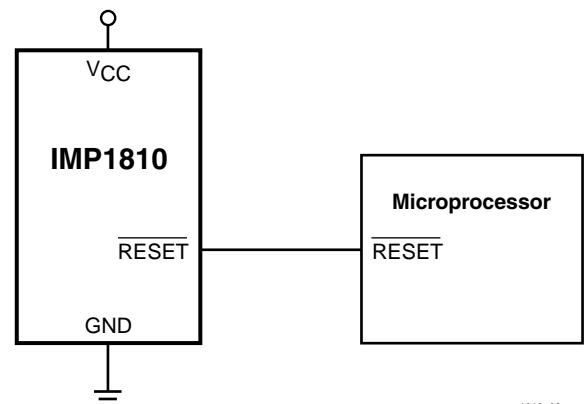

Pin Configuration

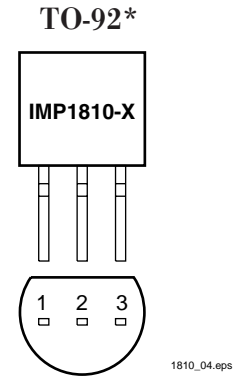
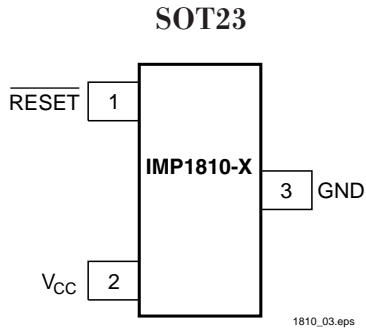

Pin Descriptions

Pin Number	Name	Function
1	RESET	Active LOW reset output
2	V _{CC}	Power supply input
3	GND	Ground

Package Marking Code

SOT-23 Package Letter Code			
A	B	Part	Reset Tolerance
B	A	IMP1810	5%
B	B	IMP1810	10%
B	C	IMP1810	15%

1810_102.eps

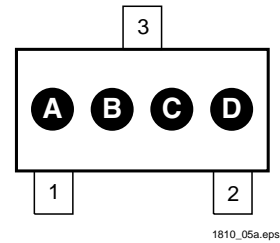

Ordering Information

Device Summary								Package Marking			
Part**	RESET Output Voltage (V)	RESET Tolerance (%)	RESET Time (ms)	Push-Pull Output Stage	TO-92* Package	SOT-23 Package	RESET Polarity	A	B	C	D
IMP1810-5	4.62	5	150	●	●		LOW				
IMP1810-10	4.37	10	150	●	●		LOW				
IMP1810-15	4.12	15	150	●	●		LOW				
IMP1810R-5	4.62	5	150	●		●	LOW	B	A	X	X
IMP1810R-10	4.37	10	150	●		●	LOW	B	B	X	X
IMP1810R-15	4.12	15	150	●		●	LOW	B	C	X	X

* Add /S to Part Number for straight (unformed) leads. (ie. IMP18xx-x/S)

** Add /T to Part Number for Tape and Reel. (ie. IMP18xx-x/T)

XX = Date code

Absolute Maximum Ratings

Voltage on $\overline{V_{CC}}$ -0.5V to 7V
 Voltage on \overline{RESET} -0.5V to $V_{CC} + 0.5V$
 Operating Temperature Range -40°C to 85°C

Soldering Temperature 260°C for 10 seconds
 Storage Temperature -55°C to 125°C

*Voltages measured with respect to ground.
 These are stress ratings only and functional operation is not implied.*

Electrical Characteristics

Unless otherwise noted, $V_{CC} = 1.2V$ to $5.5V$ and specifications are over the operating temperature range of -40°C to +85°C.
 All voltages are referenced to ground.

Parameter	Symbol	Conditions	Min	Typ	Max	Units
Supply Voltage	V_{CC}		1.2		5.5	V
Output Voltage	V_{OH}	$I_{OUT} < 500\mu A$	$V_{CC} - 0.5V$	$V_{CC} - 0.1V$		V
Output Current	I_{OH}	Output = 2.4V, $V_{CC} \geq 2.7V$		350		μA
Output Current	I_{OL}	Output = 0.4V, $V_{CC} \geq 2.7V$	+10			mA
Operating Current	I_{CC}	$V_{CC} < 5.5V$, \overline{RESET} output open		8	20	μA
V_{CC} Trip Point (IMP1810-5)	V_{CCTP}		4.50	4.62	4.75	V
V_{CC} Trip Point (IMP1810-10)	V_{CCTP}		4.25	4.37	4.49	V
V_{CC} Trip Point (IMP1810-15)	V_{CCTP}		4.00	4.12	4.24	V
Output Capacitance	C_{OUT}				10	pF
V_{CC} Detect to \overline{RESET} Low	t_{RPD}			2	5	μs
V_{CC} Slew Rate (V_{CCTP} (MAX) to V_{CCTP} (MIN))	t_F		300			μs
V_{CC} Slew Rate (V_{CCTP} (MIN) to V_{CCTP} (MAX))	t_R		0			ns
V_{CC} Detect to \overline{RESET} High	t_{RPU}	$t_r = 5\mu s$	100	150	300	ms

Notes 1. The t_F value is for reference in defining values for t_{RPD} and should not be considered a requirement for proper operation or use.

Application Information

Operation – Power Monitor

The DS1810 detects out-of-tolerance power supply conditions. It resets a processor during power-up, power-down and issues a reset to the system processor when the monitored power supply voltage is below the reset threshold. When an out-of-tolerance V_{CC} voltage is detected, the $\overline{\text{RESET}}$ signal is asserted. On power-up, $\overline{\text{RESET}}$ is kept active (LOW) for approximately 150ms after the power supply voltage has reached the selected tolerance. This allows the power supply and microprocessor to stabilize before $\overline{\text{RESET}}$ is released.

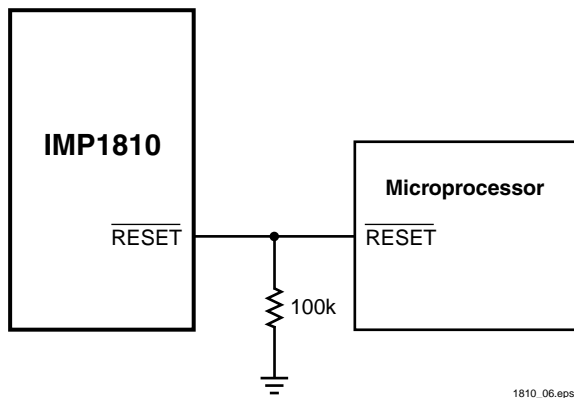

Figure 1. $\overline{\text{RESET}}$ Valid to 0V V_{CC}

Output Conditions

The IMP1810 active LOW reset signal is valid as long as V_{CC} remains above 1.2V. The $\overline{\text{RESET}}$ output on the IMP1810 uses a push-pull drive stage that can maintain a valid output below 1.2V. To sink current with V_{CC} below 1.2V, a resistor can be connected from the reset pin ($\overline{\text{RESET}}$) to Ground (see Figure 1). This configuration will give a valid value on the $\overline{\text{RESET}}$ output with V_{CC} approaching 0V. During both power up and down, this configuration will draw current when $\overline{\text{RESET}}$ is in the high state. A value of 100k Ω should be adequate to maintain a valid condition.

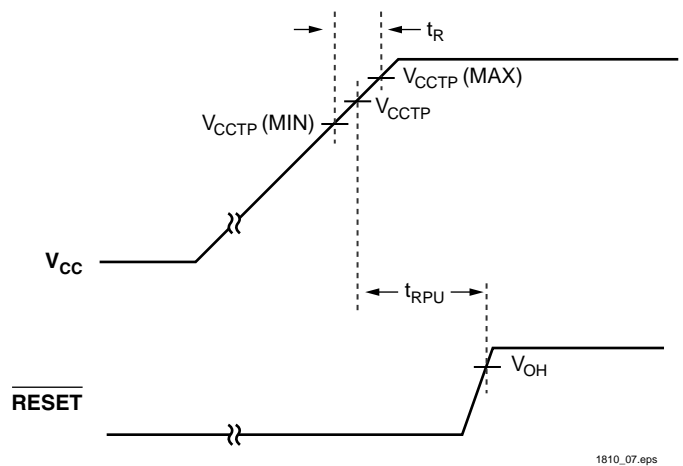

Figure 2. Timing Diagram: Power-Up

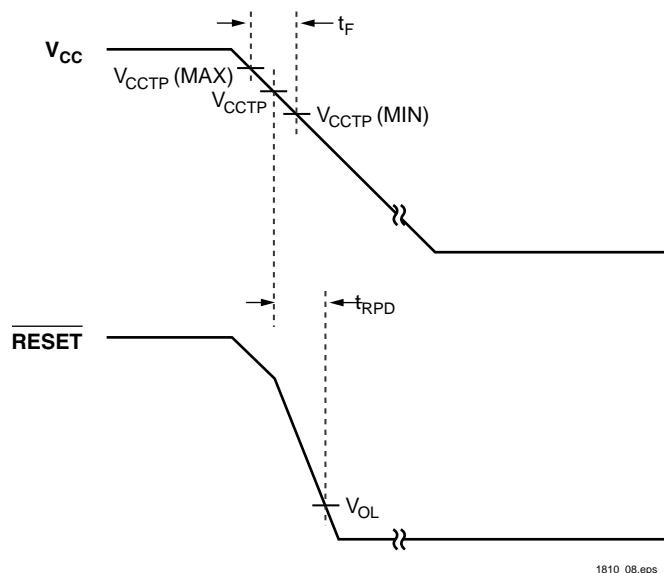

Figure 3. Timing Diagram: Power-Down

POWER MANAGEMENT

Low Power, 5V μ P Reset – Active LOW, Open-Drain Output

The IMP1811 supply voltage monitor is an improved, low-power replacement for the Dallas Semiconductor DS1811. Maximum supply current over temperature is a low 20 μ A, representing 50 percent lower power as compared to the DS1811.

The IMP1811 issues an active LOW reset signal whenever the monitored supply is out-of-tolerance. A precision reference and comparator circuit monitor power supply (V_{CC}) level. Tolerance level options are 5-, 10- and 15-percent. When an out-of-tolerance condition is detected, an internal power-fail signal is generated which forces an active LOW reset signal. After V_{CC} returns to an in-tolerance condition, the reset signal remains active for 150ms to allow the power supply and system microprocessor to stabilize.

The IMP1811 is designed with a open-drain output stage and operates over the extended industrial temperature range. Devices are available in compact surface mount SOT-23 packages and 3-lead TO-92 packages.

Other low power products in this family include the IMP1810/12/15/16/17, IMP1233D and IMP1233M.

Key Features

- ◆ Improved Dallas DS1811 replacement
 - 50% lower maximum supply current
- ◆ Low Supply Current
 - 20 μ A maximum (5.5V)
- ◆ Automatically restarts a microprocessor after power failure
- ◆ 150ms reset delay after V_{CC} returns to an in-tolerance condition
- ◆ Active LOW power-up reset
- ◆ Precision temperature-compensated voltage reference and comparator
- ◆ Eliminates external components
- ◆ Low-cost TO-92 package
- ◆ Compact surface mount SOT-23 package
- ◆ Operating temperature –40°C to +85°C

Family Selection Guide

Part	RESET Voltage (V)	RESET Time (ms)	Output Stage	RESET Polarity
IMP1810	4.620, 4.370, 4.120	150	Push-Pull	LOW
IMP1811	4.620, 4.350, 4.130	150	Open-Drain	LOW
IMP1812	4.620, 4.350, 4.130	150	Push-Pull	HIGH
IMP1815	3.060, 2.880, 2.550	150	Push-Pull	LOW
IMP1816	3.060, 2.880, 2.550	150	Open-Drain	LOW
IMP1817	3.060, 2.880, 2.550	150	Push-Pull	HIGH
IMP1233D	4.625, 4.375, 4.125	350	Open-Drain	LOW
IMP1233M	4.625, 4.375, 2.720	350	Open-Drain	LOW

Applications

- ◆ Set-top boxes
- ◆ Cellular phones
- ◆ PDAs
- ◆ Energy management systems
- ◆ Embedded control systems
- ◆ Printers
- ◆ Single board computers

Block Diagram

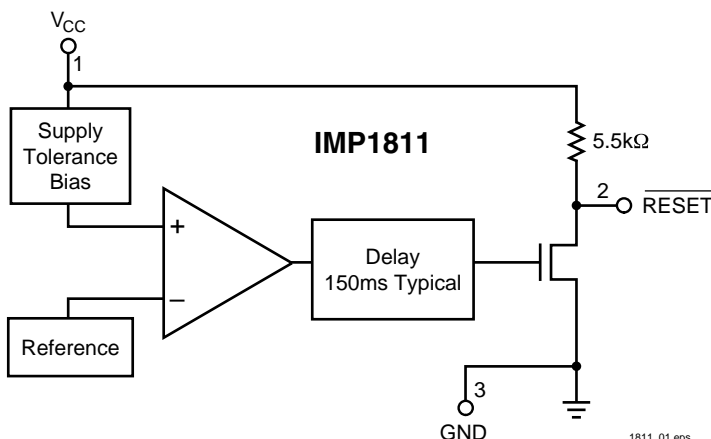

Typical Application

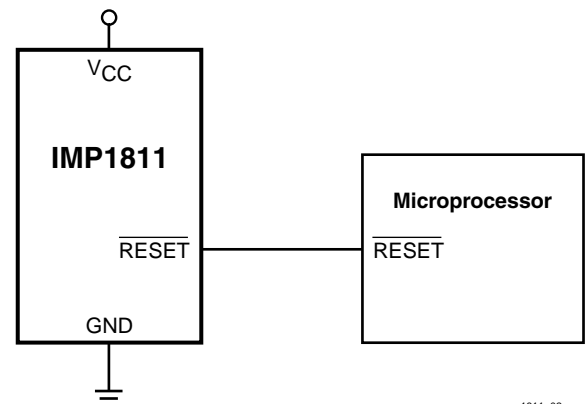

Pin Configuration

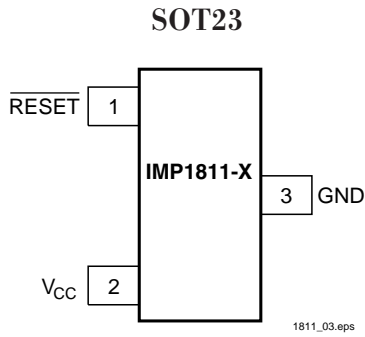

TO-92*

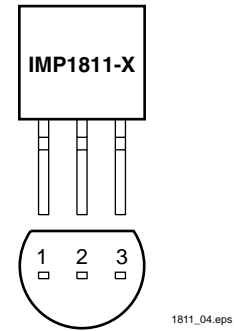

Pin Descriptions

Pin Number	Name	Function
1	RESET	Active LOW reset output
2	V _{CC}	Power supply input
3	GND	Ground

Package Marking Code

SOT-23 Package Letter Code			
A	B	Part	Reset Tolerance
C	A	IMP1811	5%
C	B	IMP1811	10%
C	C	IMP1811	15%

1811_02.eps

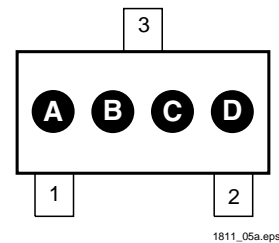

Ordering Information

Device Summary								Package Marking			
Part***	RESET Output Voltage (V)	RESET Tolerance (%)	RESET Time (ms)	Open-Drain** Output Stage	TO-92* Package	SOT-23 Package	RESET Polarity	A	B	C	D
IMP1811-5	4.62	5	150	●	●		LOW				
IMP1811-10	4.35	10	150	●	●		LOW				
IMP1811-15	4.13	15	150	●	●		LOW				
IMP1811R-5	4.62	5	150	●		●	LOW	C	A	X	X
IMP1811R-10	4.35	10	150	●		●	LOW	C	B	X	X
IMP1811R-15	4.13	15	150	●		●	LOW	C	C	X	X

* Add /S to Part Number for straight (unformed) leads. (ie. IMP18xx-x/S)

** Internal 5.5kΩ resistor pull up.

*** Add /T to Part Number for Tape and Reel. (ie. IMP18xx-x/T)

XX = Date code

Absolute Maximum Ratings

Voltage on V_{CC} -0.5V to 7V
 Voltage on $\overline{\text{RESET}}$ -0.5V to $V_{CC} + 0.5V$
 Operating Temperature Range -40°C to 85°C

Soldering Temperature 260°C for 10 seconds
 Storage Temperature -55°C to 125°C

Voltages measured with respect to ground.
 These are stress ratings only and functional operation is not implied.

Electrical Characteristics

Unless otherwise noted, $V_{CC} = 1.2V$ to $5.5V$ and specifications are over the operating temperature range of -40°C to +85°C.
 All voltages are referenced to ground.

Parameter	Symbol	Conditions	Min	Typ	Max	Units
Supply Voltage	V_{CC}		1.2		5.5	V
Output Voltage	V_{OH}	$I_{OUT} < 500\mu A$	$V_{CC} - 0.5V$	$V_{CC} - 0.1V$		V
Output Current	I_{OL}	Output = 0.4V, $V_{CC} \geq 2.7V$	+10			mA
Operating Current	I_{CC}	$V_{CC} < 5.5V$, $\overline{\text{RESET}}$ output open		8	20	μA
V_{CC} Trip Point (IMP1811-5)	V_{CCTP}		4.50	4.62	4.75	V
V_{CC} Trip Point (IMP1811-10)	V_{CCTP}		4.25	4.35	4.49	V
V_{CC} Trip Point (IMP1811-15)	V_{CCTP}		4.00	4.13	4.24	V
Internal Pull-Up Resistor	R_P		3.5	5.5	7.5	k Ω
Output Capacitance	C_{OUT}				10	pF
RESET Active Time	t_{RESET}		100	150	250	ms
V_{CC} Detect to $\overline{\text{RESET}}$ Low	t_{RPD}			2	5	μs
V_{CC} Slew Rate (V_{CCTP} (MAX) to V_{CCTP} (MIN))	t_F		300			μs
V_{CC} Slew Rate (V_{CCTP} (MIN) to V_{CCTP} (MAX))	t_R		0			ns
V_{CC} Detect to $\overline{\text{RESET}}$ High	t_{RPU}	$t_r = 5\mu s$	100	150	300	ms

Notes 1. The t_F value is for reference in defining values for t_{RPD} and should not be considered a requirement for proper operation or use.

Application Information

Operation – Power Monitor

The IMP1811 detects out-of-tolerance power supply conditions. It resets a processor during power-up, power-down and issues a reset to the system processor when the monitored power supply voltage is below the reset threshold. When an out-of-tolerance V_{CC} voltage is detected, the $\overline{\text{RESET}}$ signal is asserted. On power-up, $\overline{\text{RESET}}$ is kept active (LOW) for approximately 150ms after the power supply voltage has reached the selected tolerance. This allows the power supply and microprocessor to stabilize before $\overline{\text{RESET}}$ is released.

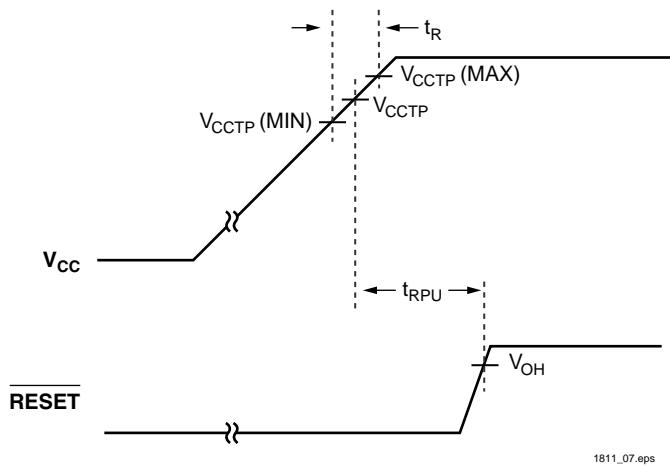

Figure 1. Timing Diagram: Power-Up

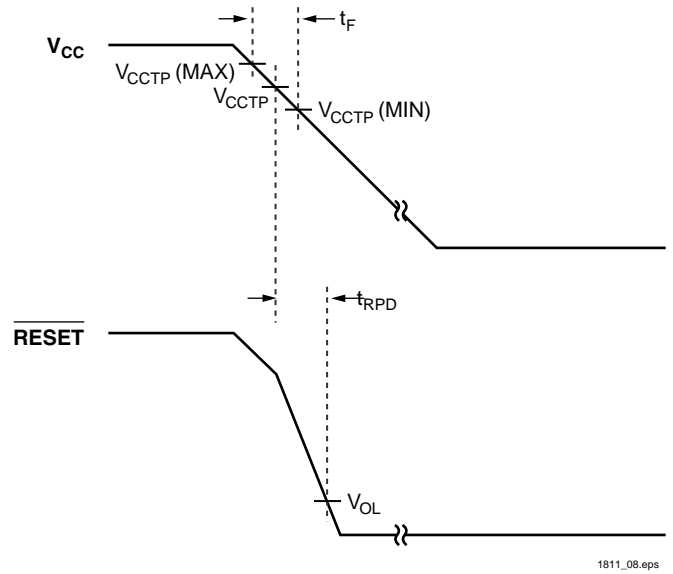

Figure 2. Timing Diagram: Power-Down

POWER MANAGEMENT

Low Power, 5V μ P Reset – Active HIGH, Push-Pull Output

The IMP1812 supply voltage monitor is an improved, low-power replacement for the Dallas Semiconductor DS1812. Maximum supply current over temperature is a low 20 μ A, representing over 50 percent lower power as compared to the DS1812.

The IMP1812 issues an active HIGH reset signal whenever the monitored supply is out-of-tolerance. A precision reference and comparator circuit monitor power supply (V_{CC}) level. Tolerance level options are 5-, 10- and 15-percent. When an out-of-tolerance condition is detected, an internal power-fail signal is generated which forces an active HIGH reset signal. After V_{CC} returns to an in-tolerance condition, the reset signal remains active for 150ms to allow the power supply and system microprocessor to stabilize.

The IMP1812 is designed with a push-pull output stage and operates over the extended industrial temperature range. Devices are available in compact surface mount SOT-23 packages and 3-lead TO-92 packages.

Other low power products in this family include the IMP1810/11/15/16/17, IMP1233D and IMP1233M.

Key Features

- ◆ Improved Dallas DS1812 replacement
 - Over 50% lower maximum supply current
- ◆ Low Supply Current
 - 20 μ A maximum (5.5V)
- ◆ Automatically restarts a microprocessor after power failure
- ◆ 150ms reset delay after V_{CC} returns to an in-tolerance condition
- ◆ Active HIGH power-up reset
- ◆ Precision temperature-compensated voltage reference and comparator
- ◆ Eliminates external components
- ◆ Low-cost TO-92 package
- ◆ Compact surface mount SOT-23 package
- ◆ Push-Pull output for minimum current drain
- ◆ Operating temperature –40°C to +85°C

Family Selection Guide

Part	RESET Voltage (V)	RESET Time (ms)	Output Stage	RESET Polarity
IMP1810	4.620, 4.370, 4.120	150	Push-Pull	LOW
IMP1811	4.620, 4.350, 4.130	150	Open-Drain	LOW
IMP1812	4.620, 4.350, 4.130	150	Push-Pull	HIGH
IMP1815	3.060, 2.880, 2.550	150	Push-Pull	LOW
IMP1816	3.060, 2.880, 2.550	150	Open-Drain	LOW
IMP1817	3.060, 2.880, 2.550	150	Push-Pull	HIGH
IMP1233D	4.625, 4.375, 4.125	350	Open-Drain	LOW
IMP1233M	4.625, 4.375, 2.720	350	Open-Drain	LOW

Applications

- ◆ Set-top boxes
- ◆ Cellular phones
- ◆ PDAs
- ◆ Energy management systems
- ◆ Embedded control systems
- ◆ Printers
- ◆ Single board computers

Block Diagram

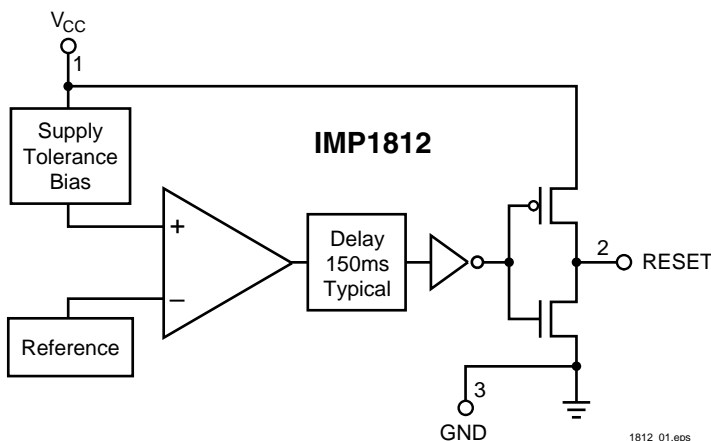

Typical Application

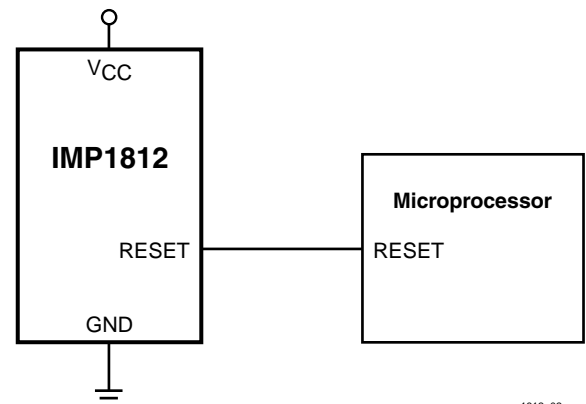

Pin Configuration

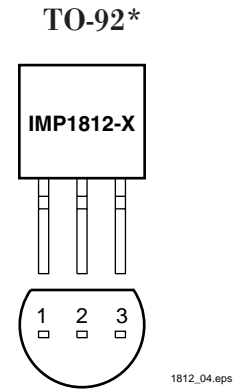
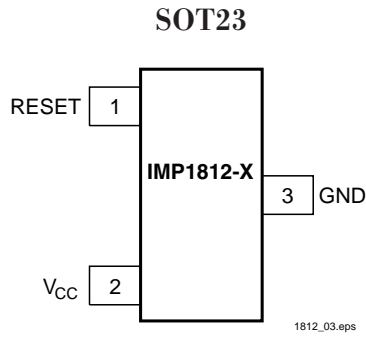

Pin Descriptions

Pin Number	Name	Function
1	RESET	Active HIGH reset output
2	V _{CC}	Power supply input
3	GND	Ground

Package Marking Code

SOT-23 Package Letter Code			
A	B	Part	Reset Tolerance
D	A	IMP1812	5%
D	B	IMP1812	10%
D	C	IMP1812	15%

1812_102.eps

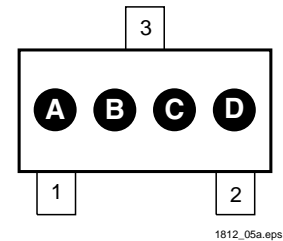

Ordering Information

Device Summary								Package Marking			
Part** Number	RESET Output Voltage (V)	RESET Tolerance (%)	RESET Time (ms)	Push-Pull Output Stage	TO-92* Package	SOT-23 Package	RESET Polarity	A	B	C	D
IMP1812-5	4.62	5	150	●	●		HIGH				
IMP1812-10	4.35	10	150	●	●		HIGH				
IMP1812-15	4.13	15	150	●	●		HIGH				
IMP1812R-5	4.62	5	150	●		●	HIGH	D	A	X	X
IMP1812R-10	4.35	10	150	●		●	HIGH	D	B	X	X
IMP1812R-15	4.13	15	150	●		●	HIGH	D	C	X	X

* Add /S to Part Number for straight (unformed) leads. (ie. IMP18xx-x/S)

** Add /T to Part Number for Tape and Reel. (ie. IMP18xx-x/T)

XX = Date code

Absolute Maximum Ratings

Voltage on V_{CC} -0.5V to 7V
 Voltage on RESET -0.5V to $V_{CC} + 0.5V$
 Operating Temperature Range -40°C to 85°C

Soldering Temperature 260°C for 10 seconds
 Storage Temperature -55°C to 125°C

*Voltages measured with respect to ground.
 These are stress ratings only and functional operation is not implied.*

Electrical Characteristics

Unless otherwise noted, $V_{CC} = 1.2V$ to $5.5V$ and specifications are over the operating temperature range of -40°C to +85°C.
 All voltages are referenced to ground.

Parameter	Symbol	Conditions	Min	Typ	Max	Units
Supply Voltage	V_{CC}		1.2		5.5	V
Output Voltage	V_{OH}	$I_{OUT} < 500\mu A$	$V_{CC} - 0.5V$	$V_{CC} - 0.1V$		V
Output Current	I_{OH}	Output = 2.4V, $V_{CC} \geq 2.7V$		350		μA
Output Current	I_{OL}	Output = 0.4V, $V_{CC} \geq 2.7V$	+10			mA
Operating Current	I_{CC}	$V_{CC} < 5.5V$, RESET output open		8	20	μA
V_{CC} Trip Point (IMP1812-5)	V_{CCTP}		4.50	4.62	4.75	V
V_{CC} Trip Point (IMP1812-10)	V_{CCTP}		4.25	4.35	4.49	V
V_{CC} Trip Point (IMP1812-15)	V_{CCTP}		4.00	4.13	4.24	V
Output Capacitance	C_{OUT}				10	pF
RESET Active Time	t_{RESET}		100	150	250	ms
V_{CC} Detect to RESET Low	t_{RPD}			2	5	μs
V_{CC} Slew Rate (V_{CCTP} (MAX) to V_{CCTP} (MIN))	t_F		300			μs
V_{CC} Slew Rate (V_{CCTP} (MIN) to V_{CCTP} (MAX))	t_R		0			ns
V_{CC} Detect to RESET High	t_{RPU}	$t_R = 5\mu s$	100	150	300	ms

Notes 1. The t_F value is for reference in defining values for t_{RPD} and should not be considered a requirement for proper operation or use.

Application Information

Operation – Power Monitor

The IMP1812 detects out-of-tolerance power supply conditions. It resets a processor during power-up, power-down and issues a reset to the system processor when the monitored power supply voltage is below the reset threshold. When an out-of-tolerance V_{CC} voltage is detected, the RESET signal is asserted. On power-up, RESET is kept active (HIGH) for approximately 150ms after the power supply voltage has reached the selected tolerance. This allows the power supply and microprocessor to stabilize before RESET is released.

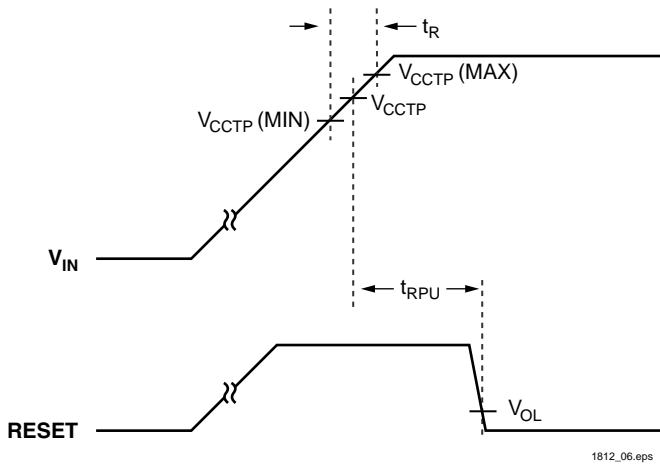

Figure 1. Timing Diagram: Power-Up

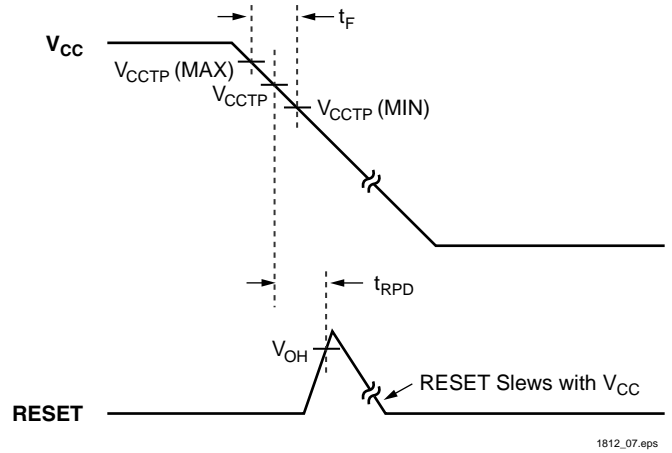

Figure 2. Timing Diagram: Power-Down

POWER MANAGEMENT

Low Power, 3.3V/3.0V μ P Reset – Active LOW, Push-Pull Output

The IMP1815 supply voltage monitor is an improved, low-power replacement for the Dallas Semiconductor DS1815. Maximum supply current over temperature is a low 15 μ A, representing over 50 percent lower power as compared to the DS1815.

The IMP1815 issues an active LOW reset signal whenever the monitored supply is out-of-tolerance. A precision reference and comparator circuit monitor power supply (V_{CC}) level. Tolerance level options are 5-, 10- and 20-percent. When an out-of-tolerance condition is detected, an internal power-fail signal is generated which forces an active LOW reset signal. After V_{CC} returns to an in-tolerance condition, the reset signal remains active for 150ms to allow the power supply and system microprocessor to stabilize.

The IMP1815 is designed with a push-pull output stage and operates over the extended industrial temperature range. Devices are available in compact surface mount SOT-23 packages and 3-lead TO-92 packages.

Other low power products in this family include the IMP1810/11/12/16/17, IMP1233D and IMP1233M.

Family Selection Guide

Part	RESET Voltage (V)	RESET Time (ms)	Output Stage	RESET Polarity
IMP1810	4.620, 4.370, 4.120	150	Push-Pull	LOW
IMP1811	4.620, 4.350, 4.130	150	Open-Drain	LOW
IMP1812	4.620, 4.350, 4.130	150	Push-Pull	HIGH
IMP1815	3.060, 2.880, 2.550	150	Push-Pull	LOW
IMP1816	3.060, 2.880, 2.550	150	Open-Drain	LOW
IMP1817	3.060, 2.880, 2.550	150	Push-Pull	HIGH
IMP1233D	4.625, 4.375, 4.125	350	Open-Drain	LOW
IMP1233M	4.625, 4.375, 2.720	350	Open-Drain	LOW

Block Diagram

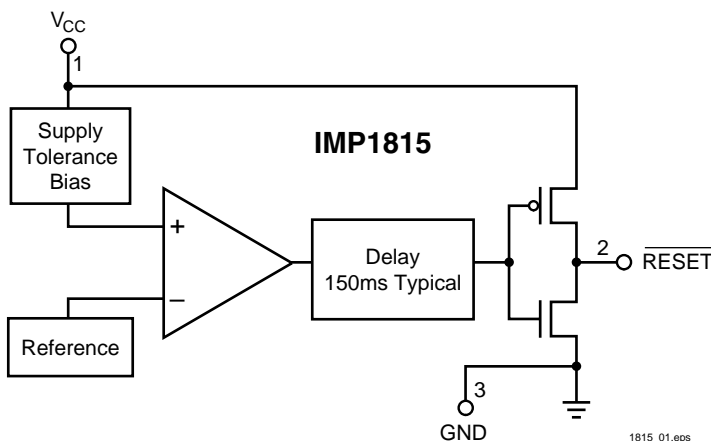

Key Features

- ◆ Improved Dallas DS1815 replacement
 - Over 50% lower maximum supply current
- ◆ Low Supply Current
 - 20 μ A maximum (5.5V)
 - 15 μ A maximum (3.6V)
- ◆ Automatically restarts a microprocessor after power failure
- ◆ 150ms reset delay after V_{CC} returns to an in-tolerance condition
- ◆ Active LOW power-up reset
- ◆ Precision temperature-compensated voltage reference and comparator
- ◆ Eliminates external components
- ◆ Low-cost TO-92 package
- ◆ Compact surface mount SOT-23 package
- ◆ Push-Pull output for minimum current drain
- ◆ Operating temperature -40°C to $+85^{\circ}\text{C}$

Applications

- ◆ Set-top boxes
- ◆ Cellular phones
- ◆ PDAs
- ◆ Energy management systems
- ◆ Embedded control systems
- ◆ Printers
- ◆ Single board computers

Typical Application

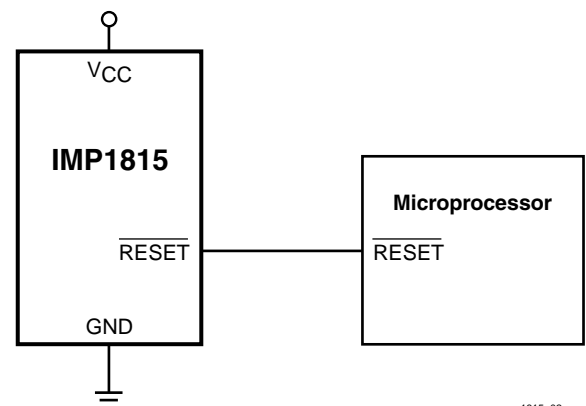

Pin Configuration

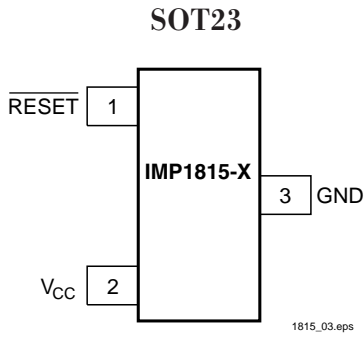

TO-92*

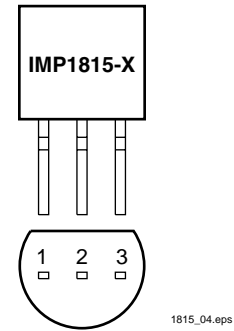

Pin Descriptions

Pin Number	Name	Function
1	RESET	Active LOW reset output
2	V _{CC}	Power supply input
3	GND	Ground

Package Marking Code

SOT-23 Package Letter Code			
A	B	Part	Reset Tolerance
E	A	IMP1815	5%
E	B	IMP1815	10%
E	D	IMP1815	20%

1815_102.eps

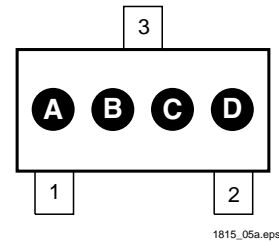

Ordering Information

Device Summary								Package Marking			
Part**	RESET Output Voltage (V)	RESET Tolerance (%)	RESET Time (ms)	Push-Pull Output Stage	TO-92* Package	SOT-23 Package	RESET Polarity	A	B	C	D
IMP1815-5	3.06	5	150	●	●		LOW				
IMP1815-10	2.88	10	150	●	●		LOW				
IMP1815-20	2.55	20	150	●	●		LOW				
IMP1815R-5	3.06	5	150	●		●	LOW	E	A	X	X
IMP1815R-10	2.88	10	150	●		●	LOW	E	B	X	X
IMP1815R-20	2.55	20	150	●		●	LOW	E	D	X	X

* Add /S to Part Number for straight (unformed) leads. (ie. IMP18xx-x/S)

** Add /T to Part Number for Tape and Reel. (ie. IMP18xx-x/T)

XX = Date code

Absolute Maximum Ratings

Voltage on V_{CC} -0.5V to 7V
 Voltage on $\overline{\text{RESET}}$ -0.5V to $V_{CC} + 0.5V$
 Operating Temperature Range -40°C to 85°C

Soldering Temperature 260°C for 10 seconds
 Storage Temperature -55°C to 125°C

*Voltages measured with respect to ground.
 These are stress ratings only and functional operation is not implied.*

Electrical Characteristics

Unless otherwise noted, $V_{CC} = 1.2V$ to $5.5V$ and specifications are over the operating temperature range of -40°C to +85°C.
 All voltages are referenced to ground.

Parameter	Symbol	Conditions	Min	Typ	Max	Units
Supply Voltage	V_{CC}		1.2		5.5	V
Output Voltage	V_{OH}	$I_{OUT} < 500\mu A$	$V_{CC} - 0.5V$	$V_{CC} - 0.1V$		V
Output Current	I_{OH}	Output = 2.4V, $V_{CC} \geq 2.7V$		350		μA
Output Current	I_{OL}	Output = 0.4V, $V_{CC} \geq 2.7V$	+10			mA
Operating Current	I_{CC}	$V_{CC} < 5.5V$, $\overline{\text{RESET}}$ output open		8	20	μA
Operating Current	I_{CC}	$V_{CC} \leq 3.6V$, $\overline{\text{RESET}}$ output open		6	15	μA
V_{CC} Trip Point (IMP1815-5)	V_{CCTP}		2.98	3.06	3.15	V
V_{CC} Trip Point (IMP1815-10)	V_{CCTP}		2.80	2.88	2.97	V
V_{CC} Trip Point (IMP1815-20)	V_{CCTP}		2.47	2.55	2.64	V
Output Capacitance	C_{OUT}				10	pF
V_{CC} Detect to $\overline{\text{RESET}}$	t_{RPD}			2	5	μs
V_{CC} Slew Rate (V_{CCTP} (MAX) to V_{CCTP} (MIN))	t_F	Note 1	300			μs
V_{CC} Slew Rate (V_{CCTP} (MIN) to V_{CCTP} (MAX))	t_R		0			ns
V_{CC} Detect to $\overline{\text{RESET}}$	t_{RPU}	$t_R = 5\mu s$	100	150	250	ms

Notes 1. The t_F value is for reference in defining values for t_{RPD} and should not be considered a requirement for proper operation or use.

Application Information

Operation – Power Monitor

The IMP1815 detects out-of-tolerance power supply conditions. It resets a processor during power-up, power-down and issues a reset to the system processor when the monitored power supply voltage is below the reset threshold. When an out-of-tolerance V_{CC} voltage is detected, the $\overline{\text{RESET}}$ signal is asserted. On power-up, $\overline{\text{RESET}}$ is kept active (LOW) for approximately 150ms after the power supply voltage has reached the selected tolerance. This allows the power supply and microprocessor to stabilize before $\overline{\text{RESET}}$ is released.

Output Conditions

The IMP1815 active LOW reset signal is valid as long as V_{CC} remains above 1.2V. The $\overline{\text{RESET}}$ output on the IMP1815 uses a push-pull drive stage that can maintain a valid output below 1.2V. To sink current with V_{CC} below 1.2V, a resistor can be connected from the reset pin ($\overline{\text{RESET}}$) to Ground (see Figure 1). This configuration will give a valid value on the $\overline{\text{RESET}}$ output with V_{CC} approaching 0V. During both power up and down, this configuration will draw current when $\overline{\text{RESET}}$ is in the high state. A value of 100k Ω should be adequate to maintain a valid condition.

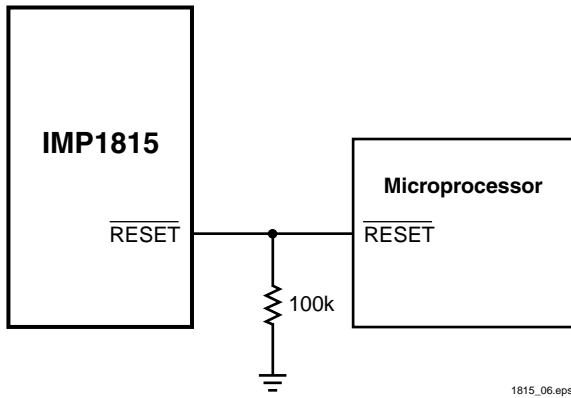

Figure 1. $\overline{\text{RESET}}$ Valid to 0V V_{CC}

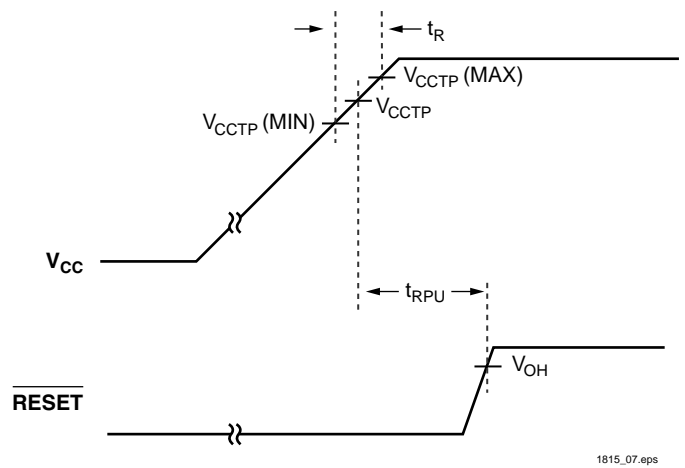

Figure 2. Timing Diagram: Power-Up

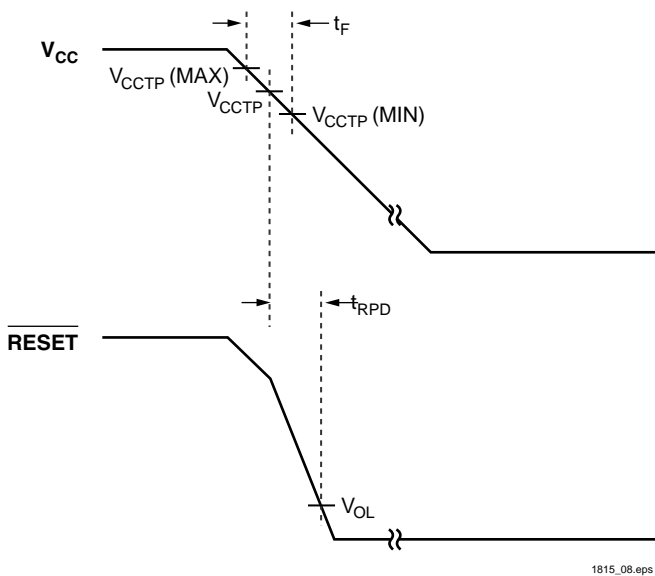

Figure 3. Timing Diagram: Power-Down

POWER MANAGEMENT

Low Power, 3.3V/3.0V μ P Reset – Active LOW, Open-Drain Output

The IMP1816 supply voltage monitor is an improved, low-power replacement for the Dallas Semiconductor DS1816. Maximum supply current over temperature is a low 15 μ A, representing over 50 percent lower power as compared to the DS1816.

The IMP1816 issues an active LOW reset signal whenever the monitored supply is out-of-tolerance. A precision reference and comparator circuit monitor power supply (V_{CC}) level. Tolerance level options are 5-, 10- and 20-percent. When an out-of-tolerance condition is detected, an internal power-fail signal is generated which forces an active LOW reset signal. After V_{CC} returns to an in-tolerance condition, the reset signal remains active for 150ms to allow the power supply and system microprocessor to stabilize.

The IMP1816 is designed with a open-drain output stage and operates over the extended industrial temperature range. Devices are available in compact surface mount SOT-23 packages and 3-lead TO-92 packages.

Other low power products in this family include the IMP1810/11/12/15/17, IMP1233D and IMP1233M.

Key Features

- ◆ Improved Dallas DS1816 replacement
 - Over 70% lower maximum supply current
- ◆ Low Supply Current
 - 20 μ A maximum (5.5V)
 - 15 μ A maximum (3.6V)
- ◆ Automatically restarts a microprocessor after power failure
- ◆ 150ms reset delay after V_{CC} returns to an in-tolerance condition
- ◆ Active LOW power-up reset
- ◆ Precision temperature-compensated voltage reference and comparator
- ◆ Eliminates external components
- ◆ Low-cost TO-92 package
- ◆ Compact surface mount SOT-23 package
- ◆ Operating temperature -40°C to $+85^{\circ}\text{C}$

Family Selection Guide

Part	RESET Voltage (V)	RESET Time (ms)	Output Stage	RESET Polarity
IMP1810	4.620, 4.370, 4.120	150	Push-Pull	LOW
IMP1811	4.620, 4.350, 4.130	150	Open-Drain	LOW
IMP1812	4.620, 4.350, 4.130	150	Push-Pull	HIGH
IMP1815	3.060, 2.880, 2.550	150	Push-Pull	LOW
IMP1816	3.060, 2.880, 2.550	150	Open-Drain	LOW
IMP1817	3.060, 2.880, 2.550	150	Push-Pull	HIGH
IMP1233D	4.625, 4.375, 4.125	350	Open-Drain	LOW
IMP1233M	4.625, 4.375, 2.720	350	Open-Drain	LOW

Applications

- ◆ Set-top boxes
- ◆ Cellular phones
- ◆ PDAs
- ◆ Energy management systems
- ◆ Embedded control systems
- ◆ Printers
- ◆ Single board computers

Block Diagram

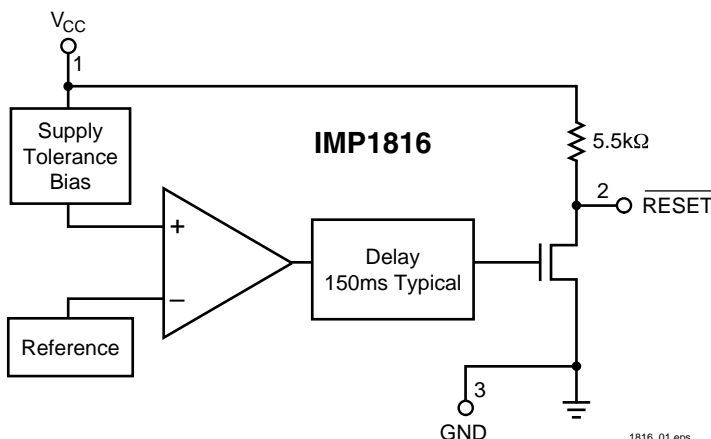

Typical Application

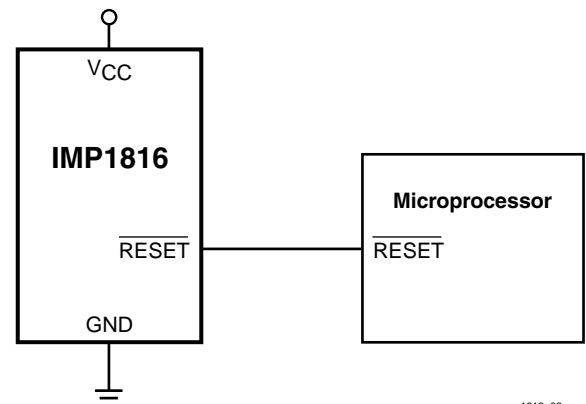

Pin Configuration

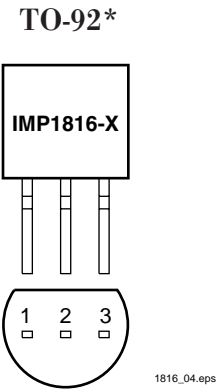
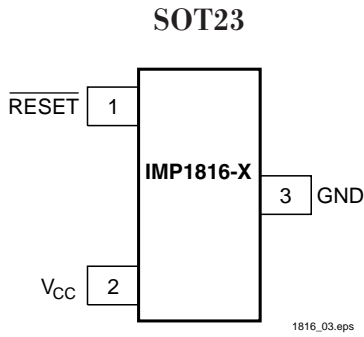

Pin Descriptions

Pin Number	Name	Function
1	RESET	Active LOW reset output
2	V _{CC}	Power supply input
3	GND	Ground

Package Marking Code

SOT-23 Package Letter Code			
A	B	Part	Reset Tolerance
K	A	IMP1816	5%
K	B	IMP1816	10%
K	D	IMP1816	20%

1816_102.eps

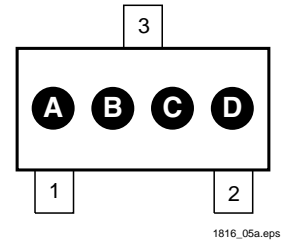

Ordering Information

Device Summary								Package Marking			
Part***	RESET Output Voltage (V)	RESET Tolerance (%)	RESET Time (ms)	Open-Drain**	TO-92* Package	SOT-23 Package	RESET Polarity	A	B	C	D
IMP1816-5	3.06	5	150	●	●		LOW				
IMP1816-10	2.88	10	150	●	●		LOW				
IMP1816-20	2.55	20	150	●	●		LOW				
IMP1816R-5	3.06	5	150	●		●	LOW	K	A	X	X
IMP1816R-10	2.88	10	150	●		●	LOW	K	B	X	X
IMP1816R-20	2.55	20	150	●		●	LOW	K	D	X	X

* Add /S to Part Number for straight (unformed) leads. (ie. IMP18xx-x/S)

** Internal 5.5kΩ resistor pull up.

*** Add /T to Part Number for Tape and Reel. (ie. IMP18xx-x/T)

XX = Date code

Absolute Maximum Ratings

Voltage on V_{CC} -0.5V to 7V
 Voltage on $\overline{\text{RESET}}$ -0.5V to $V_{CC} + 0.5V$
 Operating Temperature Range -40°C to 85°C

Soldering Temperature 260°C for 10 seconds
 Storage Temperature -55°C to 125°C

*Voltages measured with respect to ground.
 These are stress ratings only and functional operation is not implied.*

Electrical Characteristics

Unless otherwise noted, $V_{CC} = 1.2V$ to $5.5V$ and specifications are over the operating temperature range of -40°C to +85°C.
 All voltages are referenced to ground.

Parameter	Symbol	Conditions	Min	Typ	Max	Units
Supply Voltage	V_{CC}		1.2		5.5	V
Output Voltage	V_{OH}	$I_{OUT} < 500\mu A$	$V_{CC} - 0.5V$	$V_{CC} - 0.1V$		V
Output Current	I_{OL}	Output = 0.4V, $V_{CC} \geq 2.7V$	+10			mA
Operating Current	I_{CC}	$V_{CC} < 5.5V$, $\overline{\text{RESET}}$ output open		8	20	μA
Operating Current	I_{CC}	$V_{CC} \leq 3.6V$, $\overline{\text{RESET}}$ output open		6	15	μA
V_{CC} Trip Point (IMP1816-5)	V_{CCTP}		2.98	3.06	3.15	V
V_{CC} Trip Point (IMP1816-10)	V_{CCTP}		2.80	2.88	2.97	V
V_{CC} Trip Point (IMP1816-20)	V_{CCTP}		2.47	2.55	2.64	V
Internal Pull-Up Resistor	R_P		3.5	5.5	7.5	k Ω
Output Capacitance	C_{OUT}				10	pF
V_{CC} Detect to $\overline{\text{RESET}}$ Low	t_{RPD}			2	5	μs
V_{CC} Slew Rate (V_{CCTP} (MAX) to V_{CCTP} (MIN))	t_F	Note 1	300			μs
V_{CC} Slew Rate (V_{CCTP} (MIN) to V_{CCTP} (MAX))	t_R		0			ns
V_{CC} Detect to $\overline{\text{RESET}}$ High	t_{RPU}	$t_R = 5\mu s$	100	150	250	ms

Notes 1. The t_F value is for reference in defining values for t_{RPD} and should not be considered a requirement for proper operation or use.

Application Information

Operation – Power Monitor

The IMP1816 detects out-of-tolerance power supply conditions. It resets a processor during power-up, power-down and issues a reset to the system processor when the monitored power supply voltage is below the reset threshold. When an out-of-tolerance V_{CC} voltage is detected, the $\overline{\text{RESET}}$ signal is asserted. On power-up, $\overline{\text{RESET}}$ is kept active (LOW) for approximately 150ms after the power supply voltage has reached the selected tolerance. This allows the power supply and microprocessor to stabilize before $\overline{\text{RESET}}$ is released.

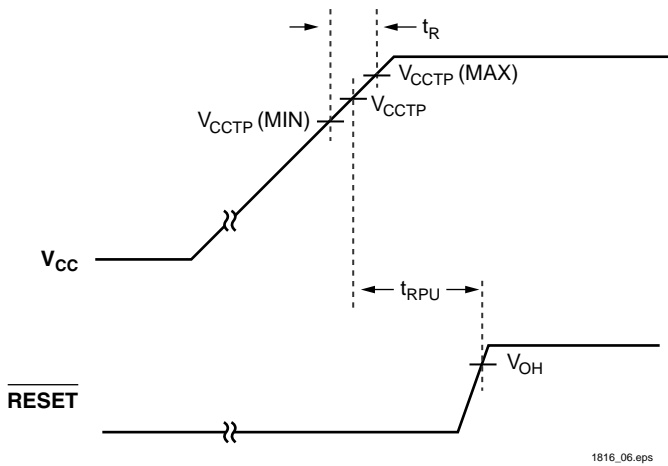

Figure 1. Timing Diagram: Power-Up

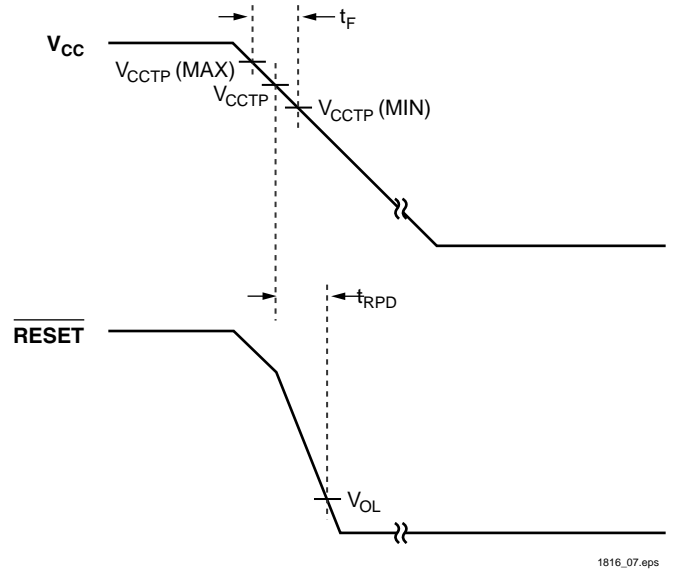

Figure 2. Timing Diagram: Power-Down

POWER MANAGEMENT

Low Power, 3.3V/3.0V μ P Reset - Active HIGH, Push-Pull Output

The IMP1817 supply voltage monitor is an improved, low-power replacement for the Dallas Semiconductor DS1817. Maximum supply current over temperature is a low 15 μ A, representing over 50 percent lower power as compared to the DS1817.

The IMP1817 issues an active HIGH reset signal whenever the monitored supply is out-of-tolerance. A precision reference and comparator circuit monitor power supply (V_{CC}) level. Tolerance level options are 5-, 10- and 20-percent. When an out-of-tolerance condition is detected, an internal power-fail signal is generated which forces an active HIGH reset signal. After V_{CC} returns to an in-tolerance condition, the reset signal remains active for 150ms to allow the power supply and system microprocessor to stabilize.

The IMP1817 is designed with a push-pull output stage and operates over the extended industrial temperature range. Devices are available in compact surface mount SOT-23 packages and 3-lead TO-92 packages.

Other low power products in this family include the IMP1810/11/12/15/16, IMP1233D and IMP1233M.

Family Selection Guide

Part	RESET Voltage (V)	RESET Time (ms)	Output Stage	RESET Polarity
IMP1810	4.620, 4.370, 4.120	150	Push-Pull	LOW
IMP1811	4.620, 4.350, 4.130	150	Open-Drain	LOW
IMP1812	4.620, 4.350, 4.130	150	Push-Pull	HIGH
IMP1815	3.060, 2.880, 2.550	150	Push-Pull	LOW
IMP1816	3.060, 2.880, 2.550	150	Open-Drain	LOW
IMP1817	3.060, 2.880, 2.550	150	Push-Pull	HIGH
IMP1233D	4.625, 4.375, 4.125	350	Open-Drain	LOW
IMP1233M	4.625, 4.375, 2.720	350	Open-Drain	LOW

Block Diagram

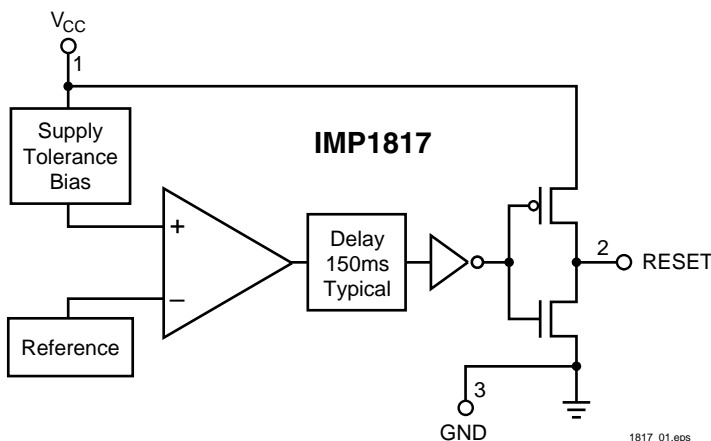

Key Features

- ◆ Improved Dallas DS1817 replacement
 - Over 50% lower maximum supply current
- ◆ Low Supply Current
 - 20 μ A maximum (5.5V)
 - 15 μ A maximum (3.6V)
- ◆ Automatically restarts a microprocessor after power failure
- ◆ 150ms reset delay after V_{CC} returns to an in-tolerance condition
- ◆ Active HIGH power-up reset
- ◆ Precision temperature-compensated voltage reference and comparator
- ◆ Eliminates external components
- ◆ Low-cost TO-92 package
- ◆ Compact surface mount SOT-23 package
- ◆ Push-Pull output for minimum current drain
- ◆ Operating temperature -40°C to $+85^{\circ}\text{C}$

Applications

- ◆ Set-top boxes
- ◆ Cellular phones
- ◆ PDAs
- ◆ Energy management systems
- ◆ Embedded control systems
- ◆ Printers
- ◆ Single board computers

Typical Application

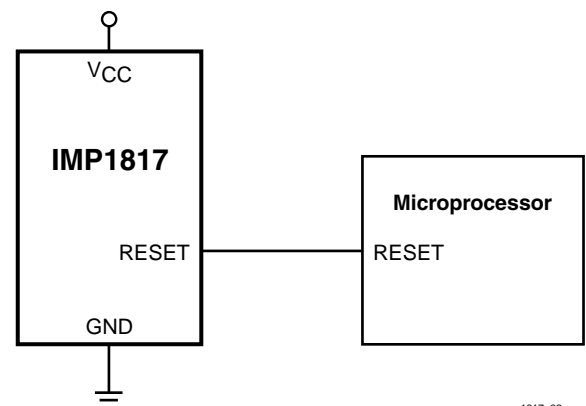

Pin Configuration

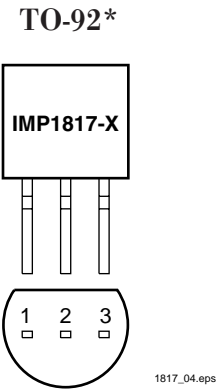
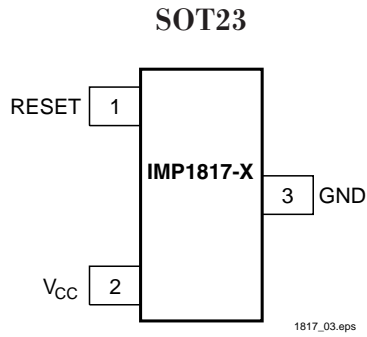

Pin Descriptions

Pin Number	Name	Function
1	RESET	Active LOW reset output
2	V _{CC}	Power supply input
3	GND	Ground

Package Marking Code

SOT-23 Package Letter Code			
A	B	Part	Reset Tolerance
M	A	IMP1817	5%
M	B	IMP1817	10%
M	C	IMP1817	20%

1817_02.eps

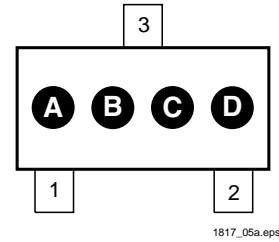

Ordering Information

Device Summary								Package Marking			
Part**	RESET Output Voltage (V)	RESET Tolerance (%)	RESET Time (ms)	Push-Pull Output Stage	TO-92* Package	SOT-23 Package	RESET Polarity	A	B	C	D
IMP1817-5	3.06	5	150	●	●		LOW				
IMP1817-10	2.88	10	150	●	●		LOW				
IMP1817-20	2.55	20	150	●	●		LOW				
IMP1817R-5	3.06	5	150	●		●	LOW	M	A	X	X
IMP1817R-10	2.88	10	150	●		●	LOW	M	B	X	X
IMP1817R-20	2.55	20	150	●		●	LOW	M	C	X	X

* Add /S to Part Number for straight (unformed) leads. (ie. IMP18xx-x/S)

** Add /T to Part Number for Tape and Reel. (ie. IMP18xx-x/T)

XX = Date code

Absolute Maximum Ratings

Voltage on V_{CC} -0.5V to 7V
 Voltage on RESET -0.5V to $V_{CC} + 0.5V$
 Operating Temperature Range -40°C to 85°C

Soldering Temperature 260°C for 10 seconds
 Storage Temperature -55°C to 125°C

*Voltages measured with respect to ground.
 These are stress ratings only and functional operation is not implied.*

Electrical Characteristics

Unless otherwise noted, $V_{CC} = 1.2V$ to $5.5V$ and specifications are over the operating temperature range of -40°C to +85°C.
 All voltages are referenced to ground.

Parameter	Symbol	Conditions	Min	Typ	Max	Units
Supply Voltage	V_{CC}		1.2		5.5	V
Output Voltage	V_{OH}	$I_{OUT} < 500\mu A$	$V_{CC} - 0.5V$	$V_{CC} - 0.1V$		V
Output Current	I_{OH}	Output = 2.4V, $V_{CC} \geq 2.7V$		350		μA
Output Current	I_{OL}	Output = 0.4V, $V_{CC} \geq 2.7V$	+10			mA
Operating Current	I_{CC}	$V_{CC} < 5.5V$, RESET output open		8	20	μA
Operating Current	I_{CC}	$V_{CC} \leq 3.6V$, RESET output open		6	15	μA
V_{CC} Trip Point (IMP1817-5)	V_{CCTP}		2.98	3.06	3.15	V
V_{CC} Trip Point (IMP1817-10)	V_{CCTP}		2.80	2.88	2.97	V
V_{CC} Trip Point (IMP1817-20)	V_{CCTP}		2.47	2.55	2.64	V
Output Capacitance	C_{OUT}				10	pF
V_{CC} Detect to RESET Low	t_{RPD}			2	5	μs
V_{CC} Slew Rate (V_{CCTP} (MAX) to V_{CCTP} (MIN))	t_F	Note 1	300			μs
V_{CC} Slew Rate (V_{CCTP} (MIN) to V_{CCTP} (MAX))	t_R		0			ns
V_{CC} Detect to RESET High	t_{RPU}	$t_R = 5\mu s$	100	150	250	ms

Notes 1. The t_F value is for reference in defining values for t_{RPD} and should not be considered a requirement for proper operation or use.

Application Information

Operation – Power Monitor

The IMP1817 detects out-of-tolerance power supply conditions. It resets a processor during power-up, power-down and issues a reset to the system processor when the monitored power supply voltage is below the reset threshold. When an out-of-tolerance V_{CC} voltage is detected, the RESET signal is asserted. On power-up, RESET is kept active (HIGH) for approximately 150ms after the power supply voltage has reached the selected tolerance. This allows the power supply and microprocessor to stabilize before RESET is released.

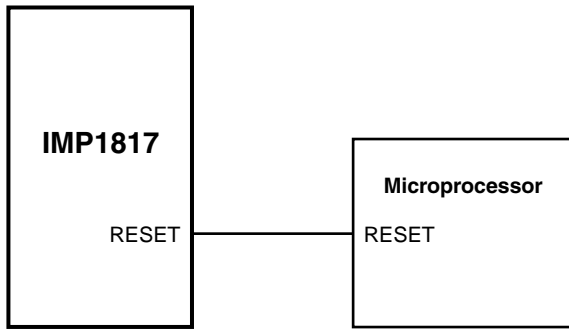

1815_07.eps

Figure 1. RESET Valid to 0V V_{CC}

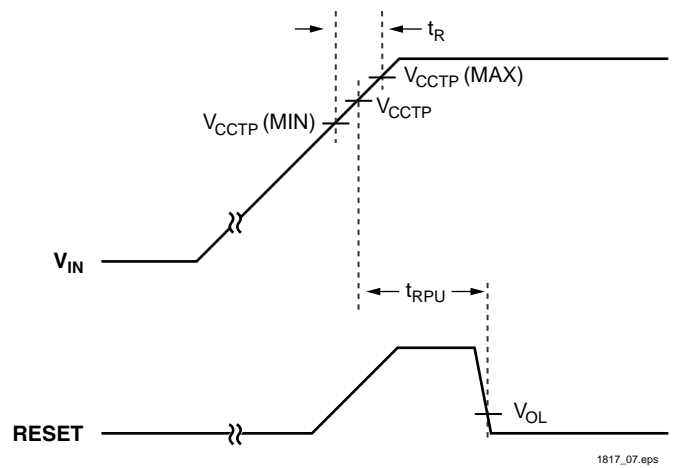

1817_07.eps

Figure 2. Timing Diagram: Power-Up

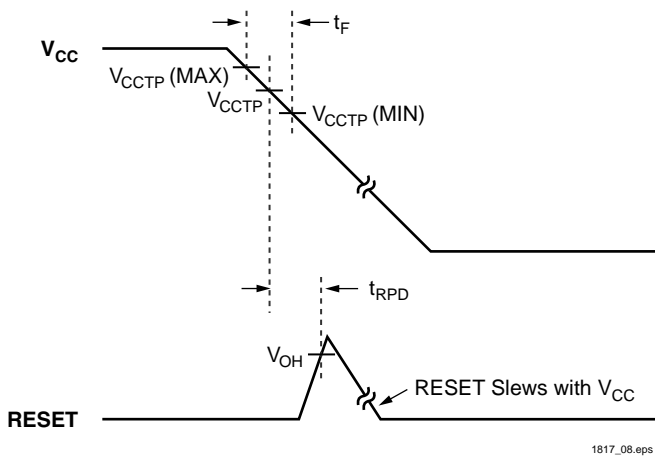

1817_08.eps

Figure 3. Timing Diagram: Power-Down

POWER MANAGEMENT

Low Power, 5V μ P Reset

- Active LOW, Open-Drain Output
- 350ms Reset Period

The IMP1233D supply voltage monitor is an improved, low-power replacement for the Dallas Semiconductor DS1233D. Maximum supply current over temperature is a low 20 μ A, representing over 60 percent lower power as compared to the DS1233D.

The IMP1233D issues an active LOW reset signal whenever the monitored supply is out-of-tolerance. A precision reference and comparator circuit monitor power supply (V_{CC}) level. Tolerance level options are 5-, 10- and 15-percent. When an out-of-tolerance condition is detected, an internal power-fail signal is generated which forces an active LOW reset signal. After V_{CC} returns to an in-tolerance condition, the reset signal remains active for 350ms to allow the power supply and system microprocessor to stabilize.

The IMP1233D is designed with an open-drain output stage and operates over the extended industrial temperature range. Devices are available in compact surface mount SOT-223 packages and 3-lead TO-92 packages.

Other low power products in this family include the IMP1810/11/12/15/16/17 and IMP1233M.

Key Features

- ◆ Improved Dallas DS1233D replacement
 - Over 60% lower maximum supply current
- ◆ Low Supply Current
 - 20 μ A maximum (5.5V)
 - 15 μ A maximum (3.6V)
- ◆ Automatically restarts a microprocessor after power failure
- ◆ 350ms reset delay after V_{CC} returns to an in-tolerance condition
- ◆ Active LOW power-up reset, 5k Ω internal pull-up
- ◆ Precision temperature-compensated voltage reference and comparator
- ◆ Eliminates external components
- ◆ Motorola 68xxx and HC16 compatible
- ◆ Low-cost TO-92 package
- ◆ Compact surface mount SOT-223 package
- ◆ Operating temperature -40 $^{\circ}$ C to +85 $^{\circ}$ C

Family Selection Guide

Part	RESET Voltage (V)	RESET Time (ms)	Output Stage	RESET Polarity
IMP1810	4.620, 4.370, 4.120	150	Push-Pull	LOW
IMP1811	4.620, 4.350, 4.130	150	Open-Drain	LOW
IMP1812	4.620, 4.350, 4.130	150	Push-Pull	HIGH
IMP1815	3.060, 2.880, 2.550	150	Push-Pull	LOW
IMP1816	3.060, 2.880, 2.550	150	Open-Drain	LOW
IMP1817	3.060, 2.880, 2.550	150	Push-Pull	HIGH
IMP1233D	4.625, 4.375, 4.125	350	Open-Drain	LOW
IMP1233M	4.625, 4.375, 2.720	350	Open-Drain	LOW

Applications

- ◆ Set-top boxes
- ◆ Cellular phones
- ◆ PDAs
- ◆ Energy management systems
- ◆ Embedded control systems
- ◆ Printers
- ◆ Single board computers

Block Diagram

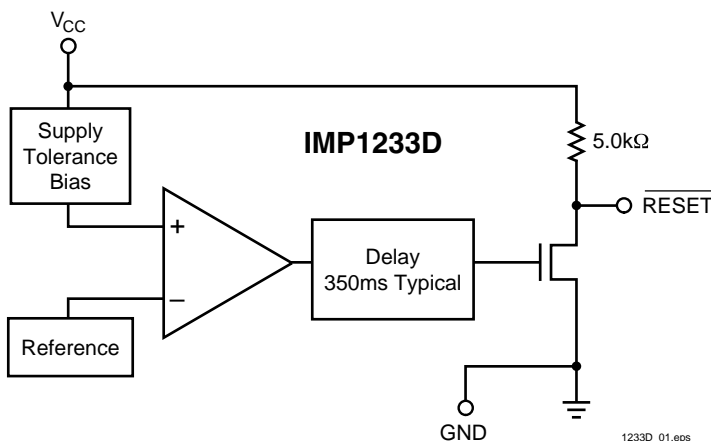

Typical Application

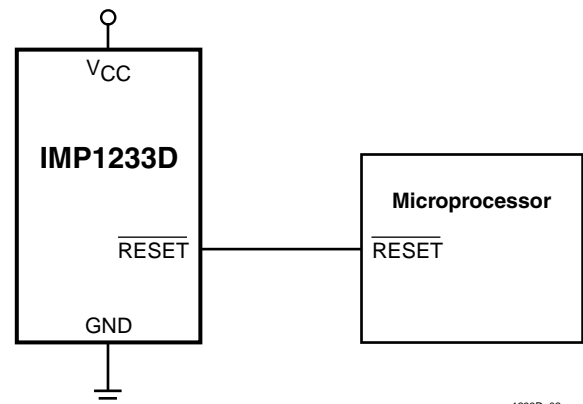

Pin Configuration

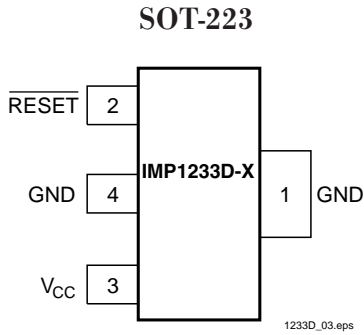

TO-92*

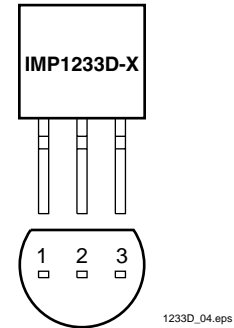

Pin Descriptions

Pin Numbers		Name	Function
SOT-223	TO-92		
1	1	GND	Ground
2	2	$\overline{\text{RESET}}$	Active LOW reset output
3	3	V _{CC}	Power supply input
4	—	GND	Ground (SOT-223 Only)

Package Marking Code

Package Letter Code			Part Type	Package Letter Code	Reset Tolerance
A	B	C			
3	3	D	IMP1233D	D	
				A	5%
				B	10%
				C	15%

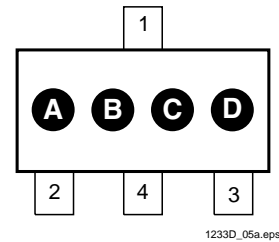

Ordering Information

Device Summary									Package Marking			
Part Number	RESET Output Voltage (V)	RESET Tolerance (%)	RESET Time (ms)	Output Stage		TO-92* Package	SOT-223** Package	RESET Polarity	A	B	C	D
				*** Open-Drain	Push-Pull							A = 5% B = 10% C = 15%
IMP1233D-5	4.625	5	350	X		X		LOW				
IMP1233D-10	4.375	10	350	X		X		LOW				
IMP1233D-15	4.125	15	350	X		X		LOW				
IMP1233DZ-5	4.625	5	350	X			X	LOW	3	3	D	A
IMP1233DZ-10	4.375	10	350	X			X	LOW	3	3	D	B
IMP1233DZ-15	4.125	15	350	X			X	LOW	3	3	D	C

* Add /S to Part Number for straight (unformed) leads. (ie. IMP1233D-xx/S)

** Add /T to Part Number for Tape and Reel. (ie. IMP1233D-xx/T)

*** Internal 5kΩ resistor pull up.

Absolute Maximum Ratings

Voltage on $\overline{V_{CC}}$ -0.5V to 7V
 Voltage on \overline{RESET} -0.5V to $V_{CC} + 0.5V$
 Operating Temperature Range -40°C to 85°C

Soldering Temperature 260°C for 10 seconds
 Storage Temperature -55°C to 125°C

*Voltages measured with respect to ground.
 These are stress ratings only and functional operation is not implied.*

Electrical Characteristics

Unless otherwise noted, $V_{CC} = 1.2V$ to $5.5V$ and specifications are over the operating temperature range of -40°C to +85°C.
 All voltages are referenced to ground.

Parameter	Symbol	Conditions	Min	Typ	Max	Units
Supply Voltage	V_{CC}		1.2		5.5	V
Output Voltage	V_{OH}	$I_{OUT} < 500\mu A$	$V_{CC} - 0.5V$	$V_{CC} - 0.1V$		V
Output Current	I_{OL}	Output = 0.4V, $V_{CC} \geq 2.7V$	+8			mA
Operating Current	I_{CC}	$V_{CC} < 5.5V$, \overline{RESET} output open		8	20	μA
Operating Current	I_{CC}	$V_{CC} \leq 3.6V$, \overline{RESET} output open		6	15	μA
V_{CC} Trip Point (IMP1233D-5)	V_{CCTP}		4.50	4.625	4.74	V
V_{CC} Trip Point (IMP1233D-10)	V_{CCTP}		4.25	4.375	4.49	V
V_{CC} Trip Point (IMP1233D-15)	V_{CCTP}		4.00	4.125	4.24	V
Internal Pull-Up Resistor	R_P		3.5	5.0	7.5	k Ω
Output Capacitance	C_{OUT}				10	pF
RESET Active Time	t_{RESET}		250	350	450	ms
V_{CC} Detect to \overline{RESET} Low	t_{RPD}			2	5	μs
V_{CC} Slew Rate ($V_{HTL} - V_{LTL}$)	t_F		300			μs
V_{CC} Slew Rate ($V_{LTL} - V_{HTL}$)	t_R		0			ns
V_{CC} Detect to \overline{RESET} High	t_{RPU}	$t_R = 5\mu s$	250	350	450	ms

Application Information

Operation – Power Monitor

The IMP1233D detects out-of-tolerance power supply conditions. It resets a processor during power-up and issues a reset to the system processor when the monitored power supply voltage is below the reset threshold (power-down). When an out-of-tolerance V_{CC} voltage is detected, the $\overline{\text{RESET}}$ signal is asserted. On power-up, $\overline{\text{RESET}}$ is kept active (LOW) for approximately 350ms after the power supply voltage has reached the selected tolerance. This allows the power supply and microprocessor to stabilize before $\overline{\text{RESET}}$ is released.

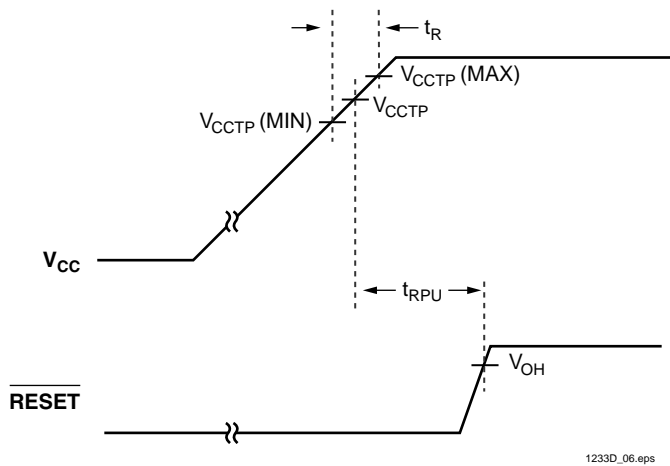

Figure 1. Timing Diagram: Power-Up

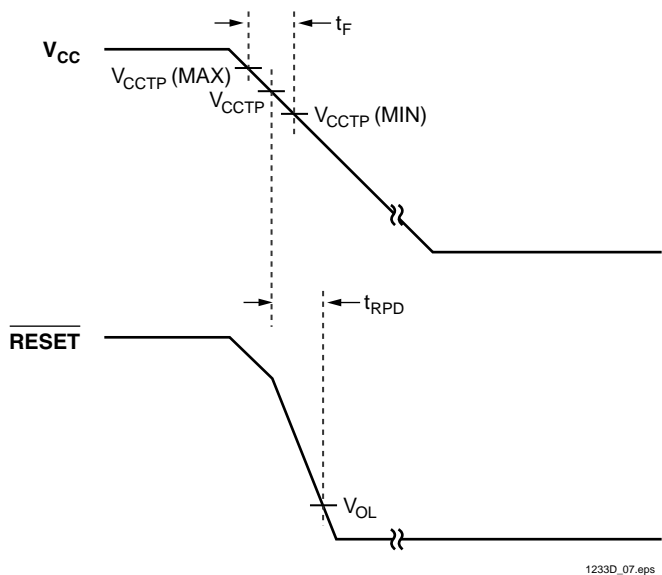

Figure 2. Timing Diagram: Power-Down

POWER MANAGEMENT

Low Power, 5V/3.0V μ P Reset

- Active LOW, Open-Drain Output
- 350ms Reset Period

The IMP1233M supply voltage monitor is an improved, low-power replacement for the Dallas Semiconductor DS1233M. Maximum supply current over temperature is a low 20 μ A, representing 60 percent lower power as compared to the DS1233M.

The IMP1233M issues an active LOW reset signal whenever the monitored supply is out-of-tolerance. A precision reference and comparator circuit monitor power supply (V_{CC}) level. Tolerance level options are 5- and 10-percent for a 5V power supply. The tolerance is 15-percent for the 3.3V, IMP1233M. When an out-of-tolerance condition is detected, an internal power-fail signal is generated which forces an active LOW reset signal. After V_{CC} returns to an in-tolerance condition, the reset signal remains active for 350ms to allow the power supply and system microprocessor to stabilize.

The IMP1233M is designed with an open-drain output stage and operates over the extended industrial temperature range. Devices are available in the compact surface mount SO-8 package and a 3-lead TO-92 package.

Other low power products in this family include the IMP1810/11/12/15/16/17 and IMP1233D.

Family Selection Guide

Part	RESET Voltage (V)	RESET Time (ms)	Output Stage	RESET Polarity
IMP1810	4.620, 4.370, 4.120	150	Push-Pull	LOW
IMP1811	4.620, 4.350, 4.130	150	Open-Drain	LOW
IMP1812	4.620, 4.350, 4.130	150	Push-Pull	HIGH
IMP1815	3.060, 2.880, 2.550	150	Push-Pull	LOW
IMP1816	3.060, 2.880, 2.550	150	Open-Drain	LOW
IMP1817	3.060, 2.880, 2.550	150	Push-Pull	HIGH
IMP1233D	4.625, 4.375, 4.125	350	Open-Drain	LOW
IMP1233M	4.625, 4.375, 2.720	350	Open-Drain	LOW

Block Diagram

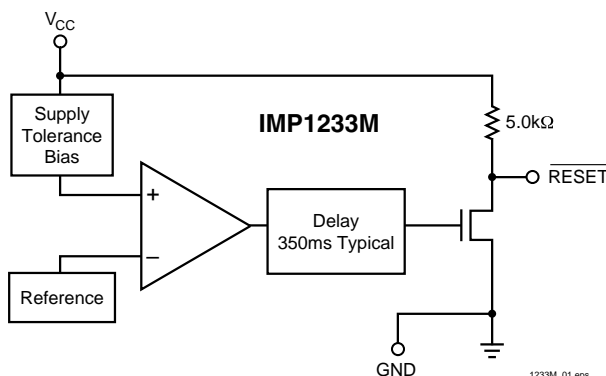

Key Features

- ◆ Improved Dallas DS1233M replacement
 - 60% lower maximum supply current
- ◆ Low Supply Current
 - 20 μ A maximum (5.5V)
 - 15 μ A maximum (3.6V)
- ◆ Automatically restarts a microprocessor after power failure
- ◆ 350ms reset delay after V_{CC} returns to an in-tolerance condition
- ◆ Active LOW power-up reset, 5k Ω internal pull-up
- ◆ Precision temperature-compensated voltage reference and comparator
- ◆ Eliminates external components
- ◆ Pin function compatible with the Motorola MC33064, MC34064, MC33164 and MC34164
- ◆ Motorola 68xxx and HC16 compatible
- ◆ Low-cost TO-92 package
- ◆ Compact surface mount SO-8 package
- ◆ Operating temperature -40°C to $+85^{\circ}\text{C}$

Applications

- ◆ Set-top boxes
- ◆ Cellular phones
- ◆ PDAs
- ◆ Energy management systems
- ◆ Embedded control systems
- ◆ Printers
- ◆ Single board computers

Typical Application

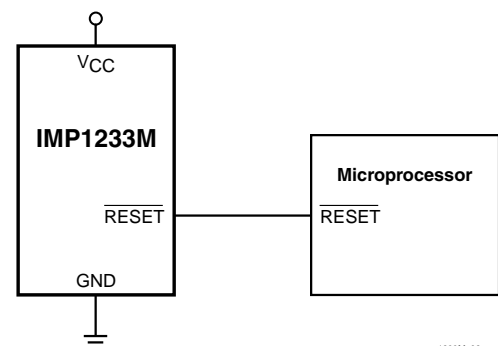

Pin Configuration

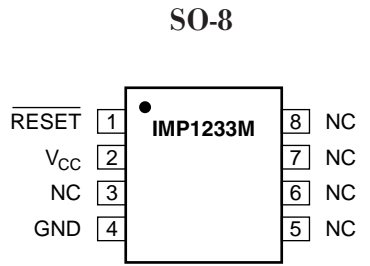

1233M_03.eps

TO-92*

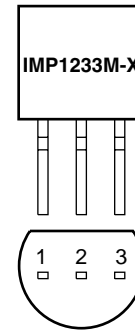

1233M_04.eps

Pin Descriptions

Pin Numbers		Name	Function
SO-8	TO-92		
1	1	$\overline{\text{RESET}}$	Active LOW reset output
2	2	V _{CC}	Power supply input
3, 5, 6, 7 and 8	—	NC	No connection
4	3	GND	Ground

Ordering Information

Device Summary								
Part Number	RESET Output Voltage (V)	RESET Tolerance (%)	RESET Time (ms)	Output Stage		TO-92* Package	SO-8 Package	RESET Polarity
				Open-Drain**	Push-Pull			
IMP1233M-55	4.625	5	350	X		X		LOW
IMP1233M-5	4.375	10	350	X		X		LOW
IMP1233M-3	2.720	15	350	X		X		LOW
IMP1233MS-55	4.625	5	350	X			X	LOW
IMP1233MS-5	4.375	10	350	X			X	LOW
IMP1233MS-3	2.720	15	350	X			X	LOW

* Add /S to Part Number for straight (unformed) leads. (ie. IMP1233M-xx/S)

** Internal 5kΩ resistor pull up.

1233M03

Absolute Maximum Ratings

Voltage on V_{CC} -0.5V to 6.5V
 Voltage on \overline{RESET} -0.5V to $V_{CC} + 0.5V$
 Operating Temperature Range -40°C to 85°C

Soldering Temperature 260°C for 10 seconds
 Storage Temperature -55°C to 125°C

*Voltages measured with respect to ground.
 These are stress ratings only and functional operation is not implied.*

Electrical Characteristics

Unless otherwise noted, $V_{CC} = 1.2V$ to $5.5V$ and specifications are over the operating temperature range of -40°C to +85°C.
 All voltages are referenced to ground.

Parameter	Symbol	Conditions	Min	Typ	Max	Units
Supply Voltage	V_{CC}		1.2		5.5	V
Output Voltage	V_{OH}	$I_{OUT} < 500\mu A$	$V_{CC} - 0.5V$	$V_{CC} - 0.1V$		V
Output Current	I_{OL}	Output = 0.4V, $V_{CC} \geq 2.7V$	+8			mA
Operating Current	I_{CC}	$V_{CC} < 5.5V$, \overline{RESET} output open		8	20	μA
Operating Current	I_{CC}	$V_{CC} \leq 3.6V$, \overline{RESET} output open		6	15	μA
V_{CC} Trip Point (IMP1233M-5)	V_{CCTP}		4.25	4.375	4.49	V
V_{CC} Trip Point (IMP1233M-55)	V_{CCTP}		4.5	4.625	4.75	V
V_{CC} Trip Point (IMP1233M-3)	V_{CCTP}		2.64	2.72	2.8	V
Voltage High Trip Level IMP1233M-5 IMP1233M-55	V_{HTL}				4.75	V
Voltage Low Trip Level IMP1233M-5 IMP1233M-55	V_{LTL}				4.00	V
Voltage High Trip Level IMP1233M-3	V_{HTL}				3.14	V
Voltage Low Trip Level IMP1233M-3	V_{LTL}				2.48	V
Internal Pull-Up Resistor	R_P		3.5	5.0	7.5	k Ω
Output Capacitance	C_{OUT}				10	pF
V_{CC} Detect to \overline{RESET} Low	t_{RPD}			2	10	μs
V_{CC} Slew Rate ($V_{HTL} - V_{LTL}$)	t_F		300			μs
V_{CC} Slew Rate ($V_{LTL} - V_{HTL}$)	t_R		0			ns
V_{CC} Detect to \overline{RESET} High	t_{RPU}	$t_R = 5\mu s$	200	350	500	ms

Notes: 1. A 1k Ω external resistor may be required in some applications for proper operation of the microprocessor reset control circuit.

Application Information

Operation – Power Monitor

The IMP1233M detects out-of-tolerance power supply conditions. It resets a processor during power-up and issues a reset to the system processor when the monitored power supply voltage is below the reset threshold (power-down). When an out-of-tolerance V_{CC} voltage is detected, the $\overline{\text{RESET}}$ signal is asserted. On power-up, $\overline{\text{RESET}}$ is kept active (LOW) for approximately 350ms after the power supply voltage has reached the selected tolerance. This allows the power supply and microprocessor to stabilize before $\overline{\text{RESET}}$ is released.

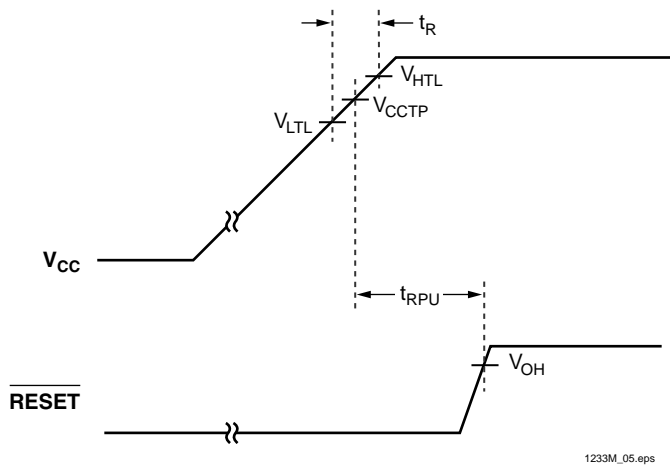

Figure 1. Timing Diagram: Power-Up

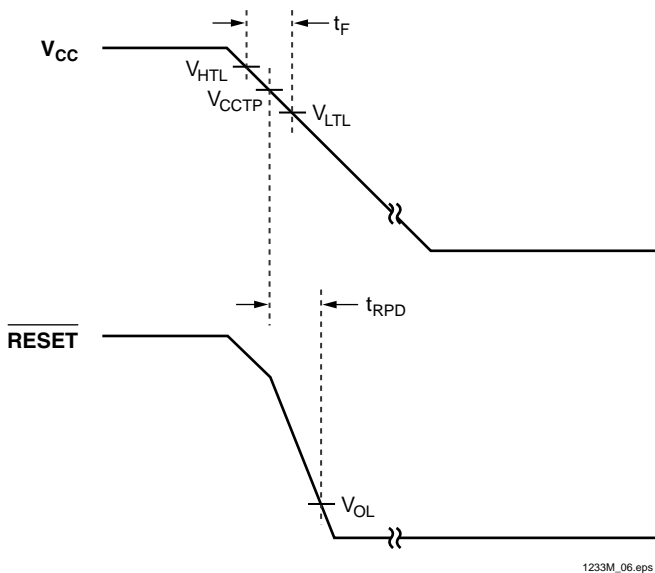
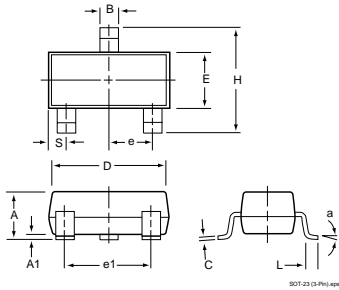

Figure 2. Timing Diagram: Power-Down

Package Dimensions

Plastic SOT-23 (3-Pin)



Plastic SOT-223 (4-Pin)

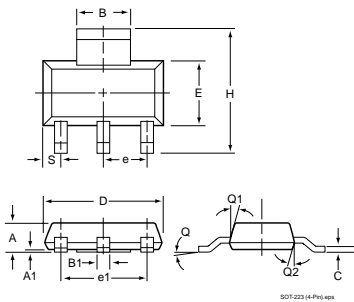

Plastic SO-8 (8-Pin)

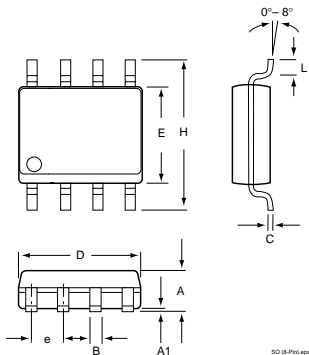

TO-92 (3-Pin)

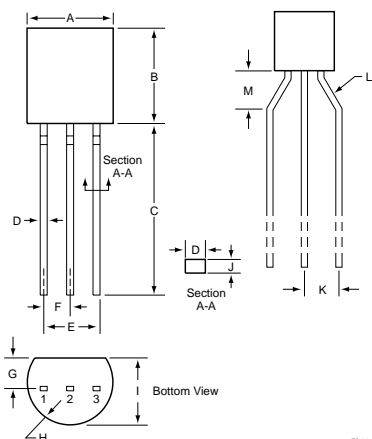

	Inches		Millimeters	
	Min	Max	Min	Max
Plastic SOT-23 (3-Pin)				
A	0.031	0.050	0.80	1.27
A1	0.004	0.010	0.10	0.25
B	0.015	0.020	0.37	0.51
C	0.003	0.007	0.085	0.18
D	0.110	0.120	2.80	3.04
E	0.047	0.055	1.20	1.40
e	0.035	0.040	0.89	1.03
e1	0.070	0.080	1.78	2.05
H	0.083	0.1039	2.10	2.64
L	0.027 REF		0.069 REF	
S	0.018	0.024	0.45	0.60
Plastic SOT-223** (4-Pin)				
A	0.067	0.060	1.70	1.50
A1	0.004	0.0008	0.10	0.02
B	0.124	0.116	3.15	2.95
B1	0.033	0.026	0.85	0.65
C	0.014	0.010	0.35	0.25
D	0.264	0.248	6.70	6.30
e	0.0905 NOM		2.30 NOM	
e1	0.181 NOM		4.50 NOM	
E	0.146	0.130	3.70	3.30
h	0.287	0.264	7.30	6.70
S	0.041	0.033	1.05	0.85
t	0.051	0.043	1.30	1.10
Q	10° MAX		10° MAX	
Q1	16°	10°	16°	10°
Q2	16°	10°	16°	10°
Plastic SO-8 (8-Pin)				
A	0.053	0.069	1.35	1.75
A1	0.004	0.010	0.10	0.25
B	0.013	0.020	0.33	0.51
C	0.007	0.010	0.19	0.25
e	0.050		1.27	
E	0.150	0.157	3.80	4.00
H	0.228	0.244	5.80	6.20
L	0.016	0.050	0.40	1.27
D	0.189	0.197	4.80	2.00
TO-92* (3-Pin)				
A	0.175	0.195	4.45	4.95
B	0.170	0.192	4.32	4.96
C	0.500	0.610	12.70	15.49
D	0.016	0.022	0.406	0.559
E	0.095	0.105	2.41	2.67
F	0.045	0.60	1.14	1.52
G	0.45	0.060	1.14	1.52
H	0.085	0.095	2.16	2.41
I	0.130	0.155	3.30	3.94
J	0.014	0.020	0.35	0.51
K	0.093	0.115	2.36	2.92
L	45°	60°	45°	60°
M	0.118 Typical		3.00	

* Formed leads are standard. Add /S to Part Number for straight leads.
 ** Add /T to Part Number for Tape and Reel.