

POWER MANAGEMENT

General Description

The IMP809/IMP810 are 3.0V, 3.3V and 5.0V power supply supervisor circuits optimized for low-power microprocessor (μ P), microcontroller (μ C) and digital systems. The IMP809/810 are improved drop-in replacements for the Maxim MAX809/810 and feature 60% lower supply current.

A reset signal is issued if the power supply voltage drops below a preset reset threshold and is asserted for at least 140ms after the supply has risen above the reset threshold. The IMP809 has an active-low RESET output that is guaranteed to be in the correct state for V_{CC} down to 1.1V. The IMP810 has an active-high RESET output. The reset comparator is designed to ignore fast transients on V_{CC} .

Low supply current makes the IMP809/IMP810 ideal for use in portable and battery operated equipment. The IMP809/IMP810 are available in a compact 3-pin SOT23 package. Six voltage thresholds are available to support 3V to 5V systems:

Reset Threshold	
Suffix	Voltage (V)
L	4.63
M	4.38
J	4.00
T	3.08
S	2.93
R	2.63
Z	2.32

Pin Assignments

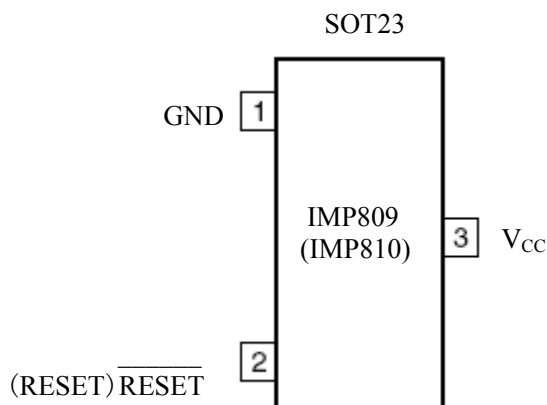

Key Features

- Improved Maxim MAX809/MAX810 replacement
 - Lower supply current...6 μ A
 - 80% lower maximum supply current
- Monitor 5V, 3.3V and 3V supplies
- 140ms min. reset pulse width
- Active-low reset valid with 1.1V supply (IMP809)
- Small 3-pin SOT-23 package
- No external components
- Specified over full temperature range
 - -40°C to 105°C

Applications

- Embedded controllers
- Battery operated systems
- Intelligent instruments
- Wireless communication systems
- PDAs and handheld equipment

POWER MANAGEMENT

Pin Descriptions

Pin Number	Name	Function
1	GND	Ground
2 (IMP809)	$\overline{\text{RESET}}$	$\overline{\text{RESET}}$ is asserted LOW if V_{CC} falls below the reset threshold and remains LOW for the 240ms typical reset timeout period (140ms minimum) after V_{CC} exceeds the threshold.
2 (IMP810)	RESET	RESET is asserted HIGH if V_{CC} falls below the reset threshold and remains HIGH for the 240ms typical reset timeout period (140ms minimum) after V_{CC} exceeds the threshold.
3	V_{CC}	Power supply input voltage (3.0V, 3.3V, 5.0V)

Absolute Maximum Ratings

Pin Terminal Voltage with Respect to Ground

V_{CC} -0.3V to 6.0V

RESET, $\overline{\text{RESET}}$ -0.3V to ($V_{CC} + 0.3V$)

Input Current at V_{CC} 20mA

Output Current: RESET, $\overline{\text{RESET}}$ 20mA

Rate of Rise at V_{CC} 100V/ μ s

Power Dissipation ($T_A = 70^\circ\text{C}$) 320mW

(Derate 4mW/ $^\circ\text{C}$ above 70 $^\circ\text{C}$)

Operating Temperature Range -40 $^\circ\text{C}$ to 105 $^\circ\text{C}$

Storage Temperature Range -65 $^\circ\text{C}$ to 160 $^\circ\text{C}$

Lead Temperature (soldering, 10 sec) 300 $^\circ\text{C}$

These are stress ratings only and functional operation is not implied. Exposure to absolute maximum ratings for prolonged time periods may affect device reliability.

Block Diagram

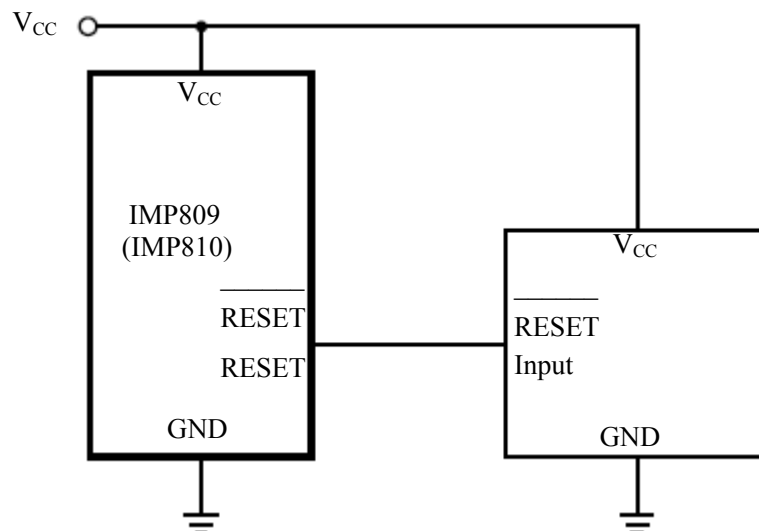

POWER MANAGEMENT

Electrical Characteristic

Unless otherwise noted V_{CC} is over the full voltage range, $T_A = -40^{\circ}\text{C}$ to 105°C .

Typical values at $T_A = 25^{\circ}\text{C}$, $V_{CC} = 5\text{V}$ for L/M/J devices, $V_{CC} = 3.3\text{V}$ for T/S devices and $V_{CC} = 3\text{V}$ for R devices.

$V_{CC}=2.5\text{V}$ for Z devices

Parameter	Symbol	Conditions	Min	Typ	Ma	Units	
Input Voltage (VCC) Range	V_{CC}	$T_A = 0^{\circ}\text{C}$ to 70°C $T_A = -40^{\circ}\text{C}$ to 105°C	1.1 1.2		5.5 5.5	V	
Supply Current	I_{CC}	$T_A = -40^{\circ}\text{C}$ to 85°C $T_A = -40^{\circ}\text{C}$ to 85°C $T_A = 85^{\circ}\text{C}$ to 105°C $T_A = 85^{\circ}\text{C}$ to 105°C	$V_{CC} < 5.5\text{V}$, L/M/J $V_{CC} < 3.6\text{V}$, R/S/T/Z $V_{CC} < 5.5\text{V}$, L/M/J $V_{CC} < 3.6\text{V}$, R/S/T/Z	9 6	15 10 25 20	μA	
Reset Threshold	V_{TH}	L devices	$T_A = 25^{\circ}\text{C}$ $T_A = -40^{\circ}\text{C}$ to 85°C $T_A = 85^{\circ}\text{C}$ to 105°C	4.56 4.50 4.40	4.63	4.70 4.75 4.86	V
		M devices	$T_A = 25^{\circ}\text{C}$ $T_A = -40^{\circ}\text{C}$ to 85°C $T_A = 85^{\circ}\text{C}$ to 105°C	4.31 4.25 4.16	4.38	4.45 4.50 4.56	
		J devices	$T_A = 25^{\circ}\text{C}$ $T_A = -40^{\circ}\text{C}$ to 85°C $T_A = 85^{\circ}\text{C}$ to 105°C	3.93 3.89 3.80	4.00	4.06 4.10 4.20	
		T devices	$T_A = 25^{\circ}\text{C}$ $T_A = -40^{\circ}\text{C}$ to 85°C $T_A = 85^{\circ}\text{C}$ to 105°C	3.04 3.00 2.92	3.08	3.11 3.15 3.23	
		S devices	$T_A = 25^{\circ}\text{C}$ $T_A = -40^{\circ}\text{C}$ to 85°C $T_A = 85^{\circ}\text{C}$ to 105°C	2.89 2.85 2.78	2.93	2.96 3.00 3.08	
		R devices	$T_A = 25^{\circ}\text{C}$ $T_A = -40^{\circ}\text{C}$ to 85°C $T_A = 85^{\circ}\text{C}$ to 105°C	2.59 2.55 2.50	2.63	2.66 2.70 2.76	
		Z devices	$T_A = 25^{\circ}\text{C}$ $T_A = -40^{\circ}\text{C}$ to 85°C $T_A = 85^{\circ}\text{C}$ to 105°C	2.27 2.24 2.22	2.32	2.37 2.39 2.42	
Reset Threshold Stability				30		ppm/ $^{\circ}\text{C}$	
VCC to Reset Delay		$V_{CC} = V_{TH}$ to $V_{TH} - 100\text{mV}$		20		μs	
Reset Active Timeout Period		$T_A = -40^{\circ}\text{C}$ to 85°C	140	240	560	ms	
		$T_A = 85^{\circ}\text{C}$ to 105°C	100		840		
Low RESET Output Voltage (IMP809)	V_{OL}	$V_{CC} = V_{TH} \text{ min.}$, $I_{SINK} = 1.2\text{mA}$, IMP809R/S/T/Z			0.3	V	
		$V_{CC} = V_{TH} \text{ min.}$, $I_{SINK} = 3.2\text{mA}$, IMP809L/M/J			0.4		
		$V_{CC} > 1.1\text{V}$, $I_{SINK} = 50\mu\text{A}$			0.3		
High RESET Output Voltage (IMP809)	V_{OH}	$V_{CC} > V_{TH} \text{ max.}$, $I_{SOURCE} = 500\mu\text{A}$, IMP809R/S/T/Z	$0.8V_{CC}$			V	
		$V_{CC} > V_{TH} \text{ max.}$, $I_{SOURCE} = 800\mu\text{A}$, IMP809L/M/J	$V_{CC} - 1.5$				
Low RESET Output Voltage (IMP810)	V_{OL}	$V_{CC} = V_{TH} \text{ max.}$, $I_{SINK} = 1.2\text{mA}$, IMP810R/S/T/Z			0.3	V	
		$V_{CC} = V_{TH} \text{ max.}$, $I_{SINK} = 3.2\text{mA}$, IMP810L/M/J			0.4		
High RESET Output Voltage (IMP810)	V_{OH}	$1.8\text{V} < V_{CC} < V_{TH} \text{ min.}$, $I_{SOURCE} = 150\mu\text{A}$	$0.8V_{CC}$			V	

POWER MANAGEMENT

Typical Performance Characteristics

Reset Timing

The reset signal is asserted–LOW for the IMP809 and HIGH for the IMP810–when the VCC signal falls below the threshold trip voltage and remains asserted for 140ms minimum after the VCC has risen above the threshold.

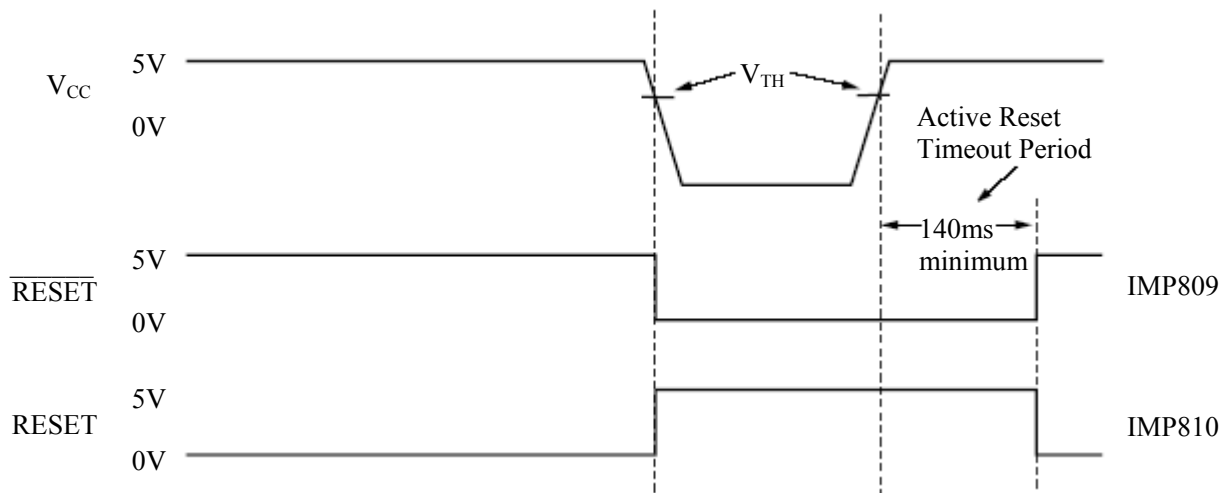

Figure 1. Reset Timing Diagram

Negative V_{CC} Transients

The IMP809/810 protect μPs from brownouts and low V_{CC} . Short duration transients of 100mV amplitude and 20 μs or less duration typically do not cause a false RESET.

Valid Reset with V_{CC} under 1.1V

To ensure logic inputs connected to the IMP809 $\overline{\text{RESET}}$ pin are in a known state when VCC is under 1.1V, a 100k Ω pull-down resistor at $\overline{\text{RESET}}$ is needed. The value is not critical. A pull-up resistor to VCC is needed with the IMP810.

POWER MANAGEMENT

Typical Performance Characteristics

(Continued)

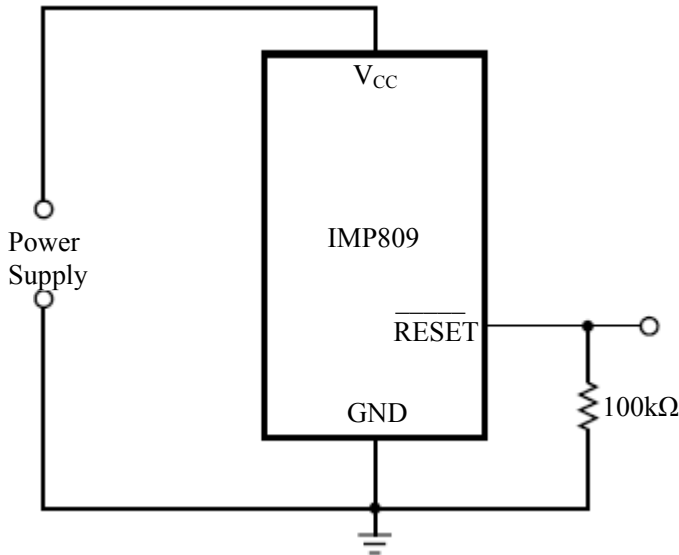

Figure 2. RESET Valid with VCC Under 1.1V

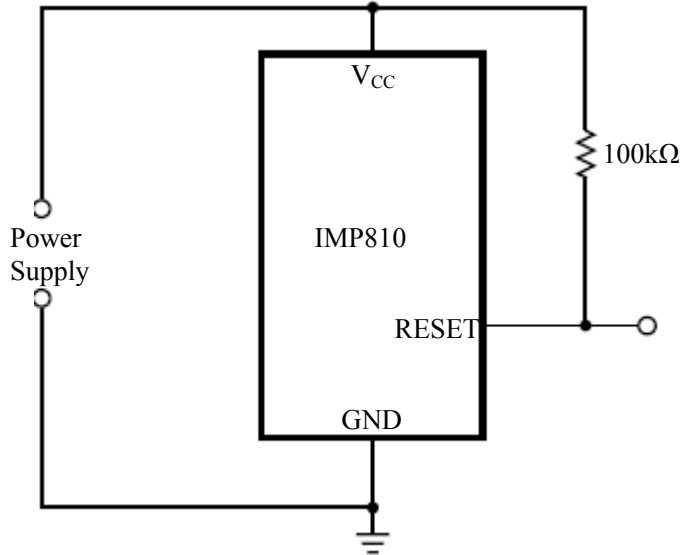

Figure 3. RESET Valid with VCC Under 1.1V

Bi-directional Reset Pin Interfacing

The IMP809/810 can interface with $\mu\text{P}/\mu\text{C}$ bi-directional reset pins by connecting a 4.7k Ω resistor in series with the IMP809/810 reset output and the $\mu\text{P}/\mu\text{C}$ bi-directional reset pin.

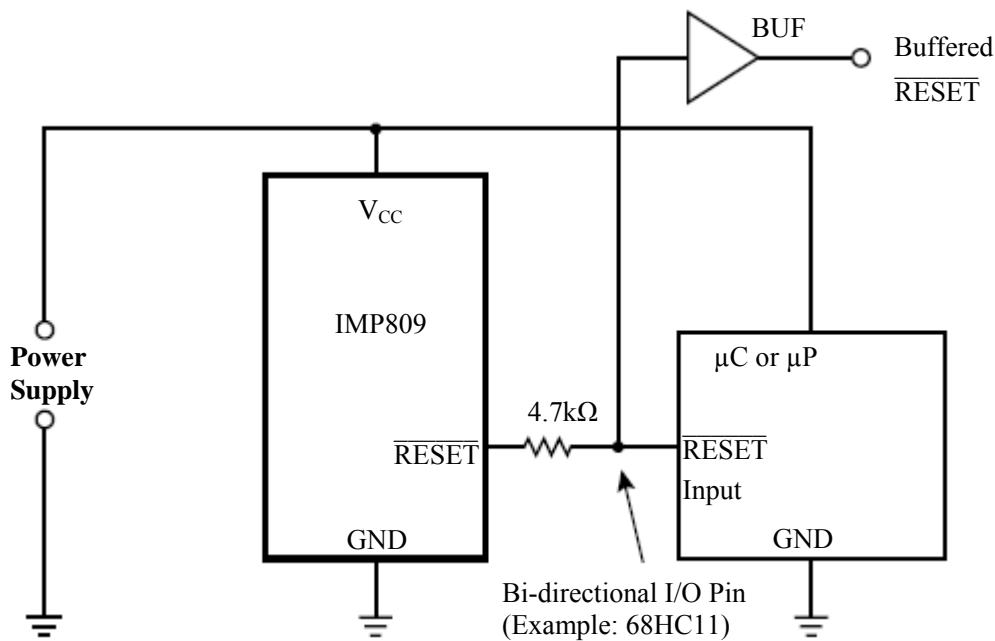

Figure 4. Bi-directional Reset Pin Interfacing

POWER MANAGEMENT

Ordering Information

Part Number ¹	Reset Threshold (V)	Temperature Range	Pin-Package	Package Marking ² (XXX Lot Code)
IMP809 Active LOW Reset				
IMP809LEUR-T	4.63	-40°C to +105°C	3-SOT23	AAXXX
IMP809MEUR-T	4.38	-40°C to +105°C	3-SOT23	ABXXX
IMP809JEUR-T	4.00	-40°C to +105°C	3-SOT23	CWXXX
IMP809TEUR-T	3.08	-40°C to +105°C	3-SOT23	ACXXX
IMP809SEUR-T	2.93	-40°C to +105°C	3-SOT23	ADXXX
IMP809REUR-T	2.63	-40°C to +105°C	3-SOT23	AFXXX
IMP809ZEUR-T	2.32	-40°C to +105°C	3-SOT23	ZAXXX
IMP810 Active HIGH Reset				
IMP810LEUR-T	4.63	-40°C to +105°C	3-SOT23	AGXXX
IMP810MEUR-T	4.38	-40°C to +105°C	3-SOT23	AHXXX
IMP810JEUR-T	4.00	-40°C to +105°C	3-SOT23	AIXXX
IMP810TEUR-T	3.08	-40°C to +105°C	3-SOT23	AJXXX
IMP810SEUR-T	2.93	-40°C to +105°C	3-SOT23	AKXXX
IMP810REUR-T	2.63	-40°C to +105°C	3-SOT23	ALXXX
IMP810ZEUR-T	2.32	-40°C to +105°C	3-SOT23	ZBXXX

Notes: 1. Tape and Reel packaging is indicated by the -T designation.

2. Devices may also be marked with full part number: 809L, 810M etc. XXX refers to lot.

Related Products

	IMP809	IMP810	IMP811	IMP812
Max. Supply Current	15μA	15μA	15μA	15μA
Package Pins	3	3	4	4
Manual RESET input			■	■
Package Type	SOT-23	SOT-23	SOT-143	SOT-143
Active-HIGH RESET output		■		■
Active-LOW RESET output	■		■	

POWER MANAGEMENT

Mechanical Dimensions

Plastic SOT-23 (3-Pin)

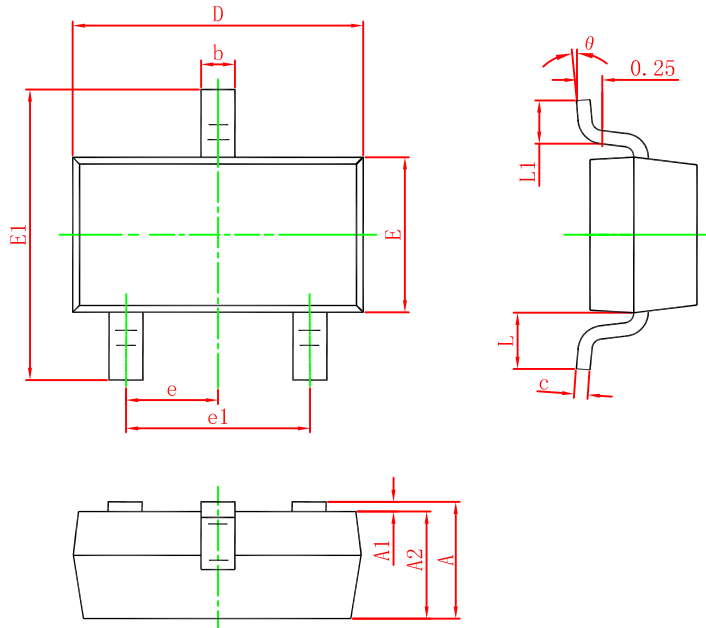

Symbol	Dimensions In Millimeters		Dimensions In Inches	
	Min.	Max.	Min.	Max.
A	0.900	1.150	0.035	0.045
A1	0.000	0.100	0.000	0.004
A2	0.900	1.050	0.035	0.041
b	0.300	0.500	0.012	0.020
c	0.080	0.150	0.003	0.006
D	2.800	3.000	0.110	0.118
E	1.200	1.400	0.047	0.055
E1	2.250	2.550	0.089	0.100
e	0.900	1.030	0.035	0.040
e1	1.800	2.000	0.071	0.079
L	0.550	0.600	0.021	0.023
L1	0.300	0.500	0.012	0.020
θ	0°	8°	0°	8°



ISO 9001 Registered

Daily Silver IMP Microelectronics Co.,Ltd
7 keda Road ,Hi-Tech Park,
NingBo,Zhejiang,P.R.C
Post Code:315040
Tel:(086)-574-87906358
Fax:(086)-574-87908866
Email:sales@ds-imp.com.cn
<http://www.ds-imp.com.cn>

The IMP logo is a registered trademark of Daily Silver IMP.
All other company and product names are trademarks of their respective owners

@2009 Daily Silver IMP
Printed in china

Revision: F
Issue Date: 14th.Jun.09
Type: Product