

UltraSCSI Terminator Family Design for UltraSCSI Performance!



- ◆ FAST-20 SCSI Operation
- ◆ New Adaptive, Non-Linear Architecture
- ◆ 35MHz Bandwidth
 - High signal integrity
 - Lower error rate
- ◆ Eliminate Costly Capacitors
- ◆ Dallas, Linfinity and Unitrode Pin-compatible

Non-Linear Terminator Family

9-Channel

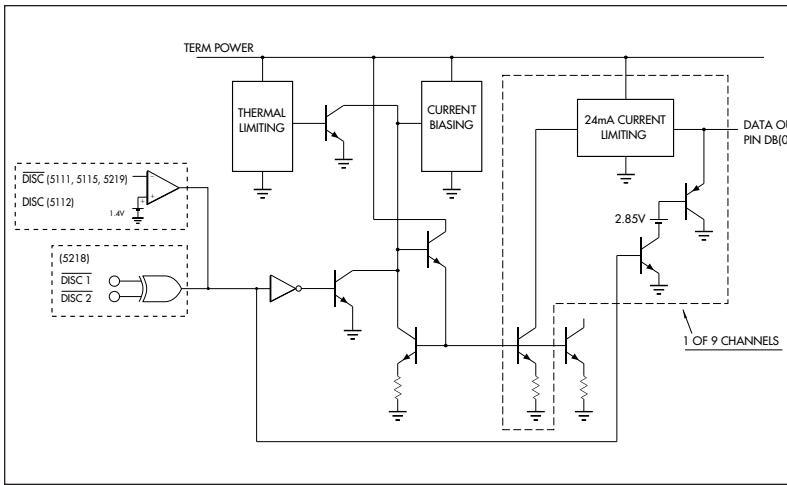

- ◆ Upgrade DS21S07A designs (IMP5115)
- ◆ Sleep-mode current under 275µA (IMP5111)
- ◆ 3.3/3.5V operation
- ◆ Less than 3pF output capacitance
- ◆ Hot-swap compatible
- ◆ 16-SOIC/16-SOWB/20-TSSOP packages

18-Channel

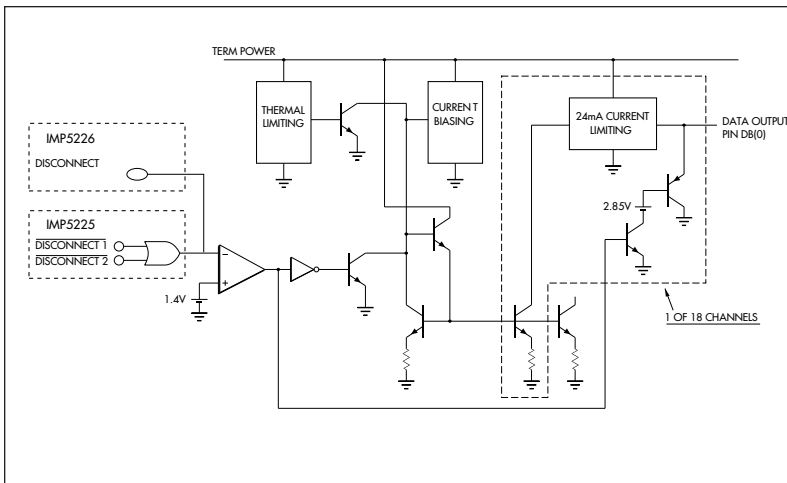

- ◆ Sleep-mode current under 200µA (IMP5226)
- ◆ Sleep-mode current under 275µA (IMP5225)
- ◆ 3.5V operation
- ◆ Less than 4pF output capacitance
- ◆ Hot-swap compatible
- ◆ 28-SSOP/28-SOWB packages

27-Channel

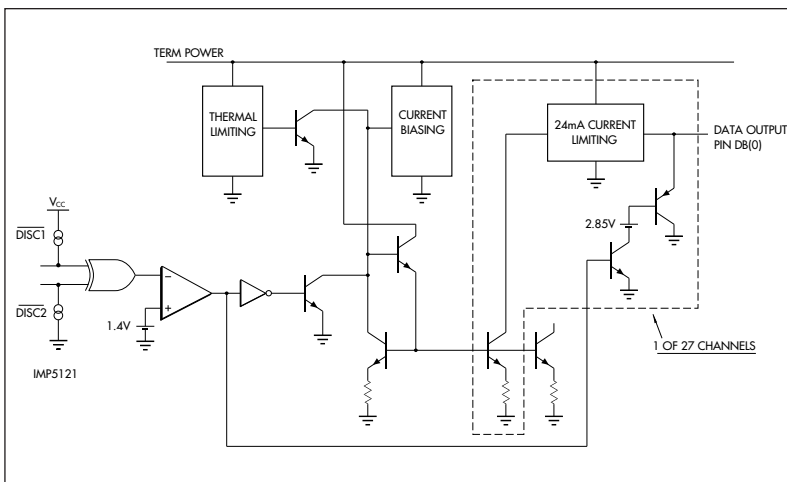

- ◆ Split dual disconnect and logic for 16/18-bit bus mixing
- ◆ Plug-and-Play
- ◆ Less than 3pF output capacitance
- ◆ Superior pin-for-pin replacement for UCC5621
- ◆ Hot-swap compatible
- ◆ 44-SSOP/56-TSSOP packages

Non-Linear Architecture Advantages

Higher Speed and Performance

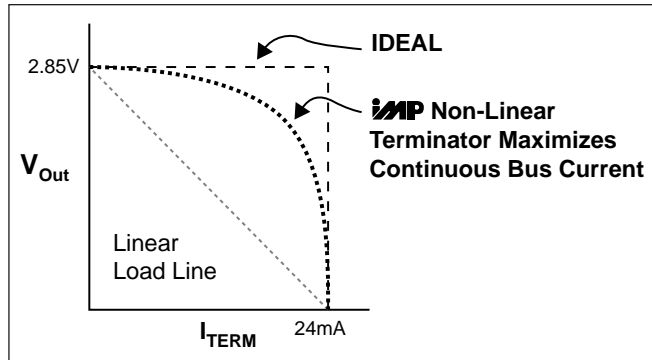

Maximum Continuous Bus Current

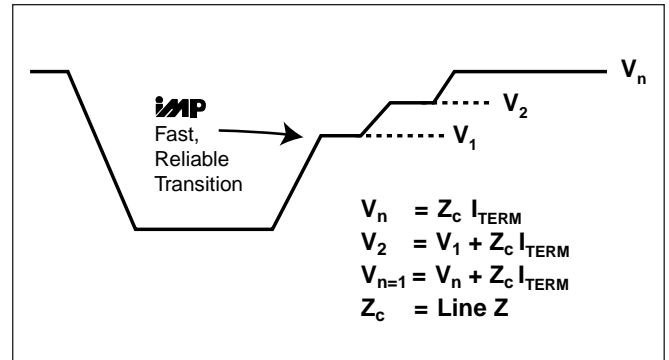

High Current Gives First-Step De-Assertion Advantage

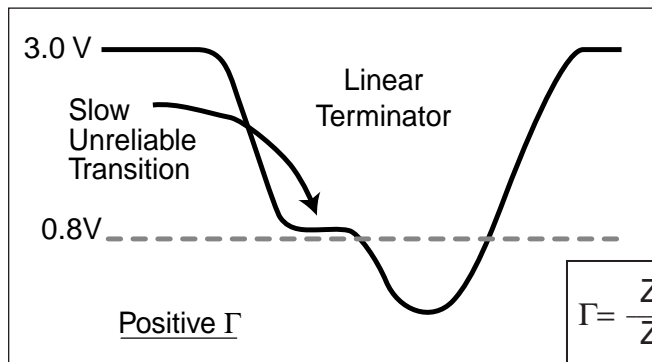

Linear Terminator Poorly Matches Loaded Cable

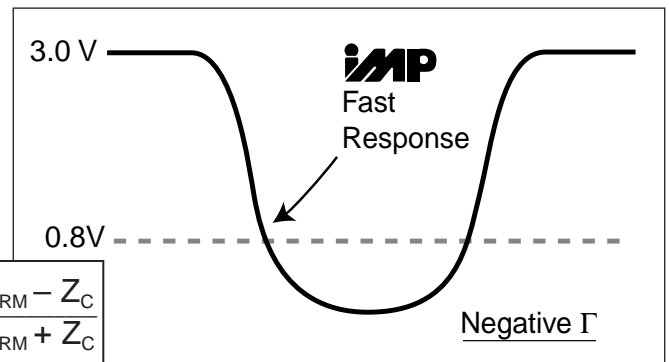

Assertion Advantage: Non-Linear Terminator Matches "Real World" System Impedance

$$\Gamma = \frac{Z_{TERM} - Z_C}{Z_{TERM} + Z_C}$$

Fewer Components

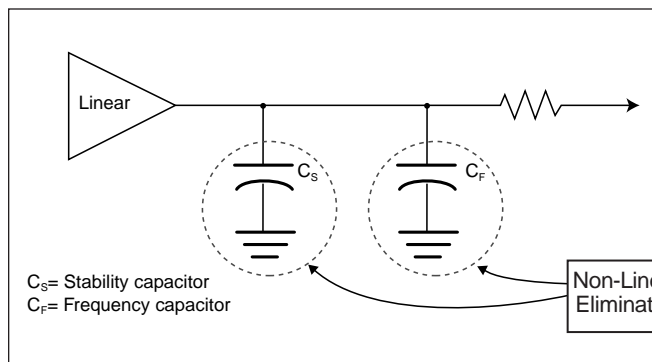

Linear Terminators Require Extra Components

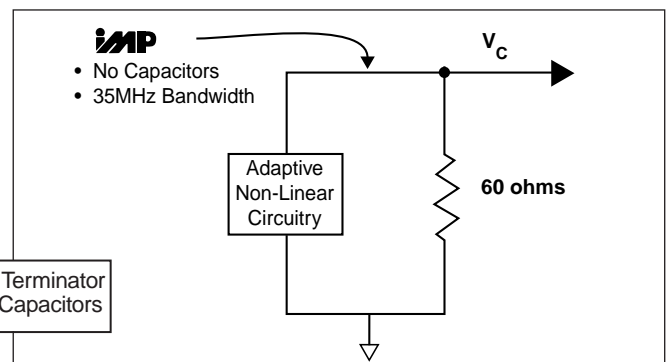

High-Bandwidth Terminator Eliminates Capacitors and Lowers Cost

Package Options

5111, 5112
SOIC

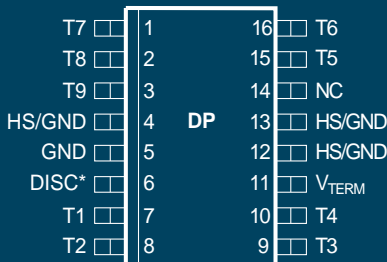

*DISC for the IMP5112
& DISC for the IMP5111

5111, 5112
TSSOP

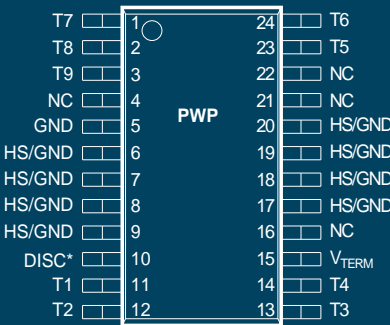

*DISC for the IMP5112
& DISC for the IMP5111

5115
SOIC

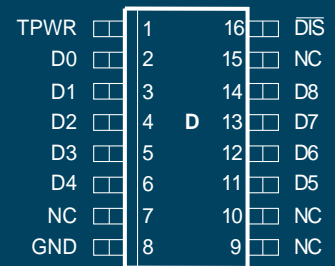

5115
SOWB

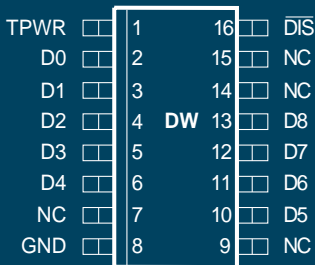

5115
TSSOP

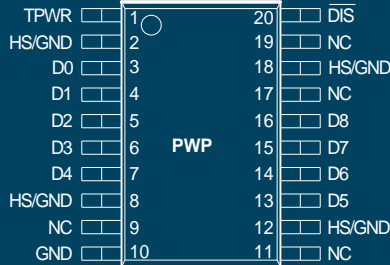

5121
SSOP

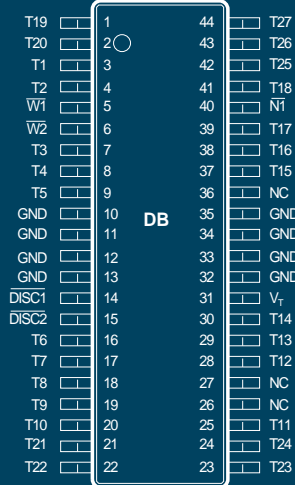

5121
TSSOP

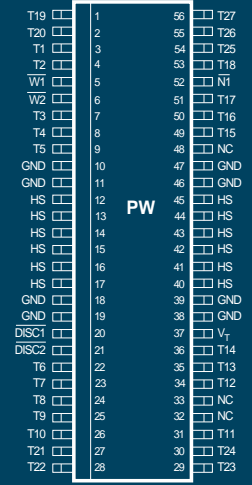

5225
SSOP

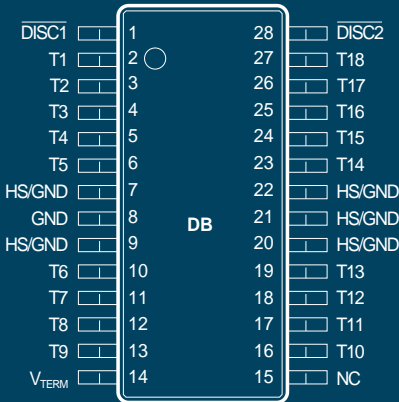

5225
SOWB

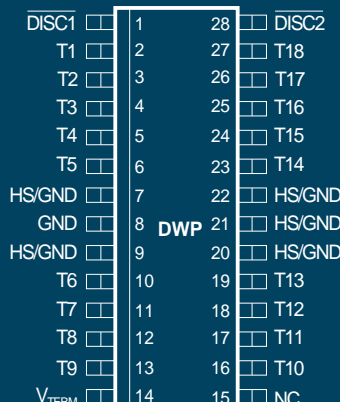

5226
SSOP

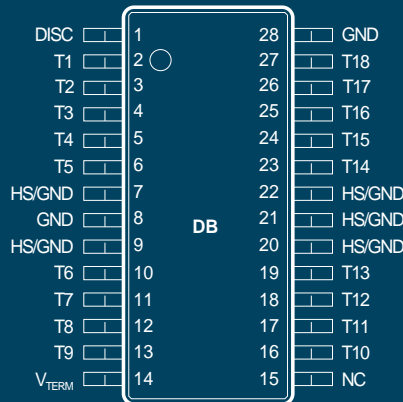

5226
SOWB

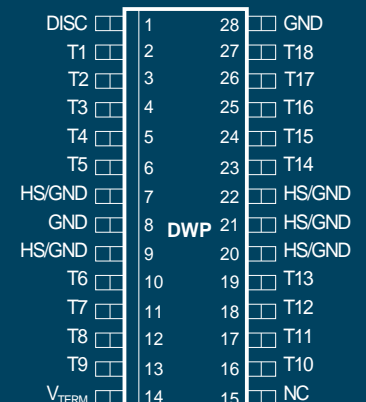

ISO 9001 Registered

Daily Silver IMP

Revision : A

Issue Date: 08/08/05

www.ds-imp.com.cn

Phone: (086)-574-87906358

Fax: (086) -574-87908866